

We encourage everyone to view the meeting live via YouTube.

***Leavenworth County
Board of County Commissioners***

Regular Meeting Agenda
300 Walnut Street, Suite 225
Leavenworth, KS 66048
November 15, 2023
9:00 a.m.

- I. CALL TO ORDER
- II. PLEDGE OF ALLEGIANCE/MOMENT OF SILENCE
- III. ROLL CALL
- IV. PUBLIC COMMENT: Public Comment shall be limited to 15 minutes at the beginning of each meeting for agenda items **only** and limited to three minutes per person. Comments at the end of the meeting shall be open to any topic of general interest to the Board of County Commissioners and limited to five minutes per person. There should be no expectation of interaction by the Commission during this time.

Anyone wishing to make comments either on items on the agenda or not are encouraged to provide their comments in writing no later than 8:00 AM the Monday immediately preceding the meeting. These comments will be included in the agenda packet for everyone to access and review. This allows the Commission to have time to fully consider input and request follow up if needed prior to the meeting.
- V. ADMINISTRATIVE BUSINESS:
- VI. CONSENT AGENDA: The items on the Consent Agenda are considered by staff to be routine business items. Approval of the items may be made by a single motion, seconded, and a majority vote with no separate discussion of any item listed. Should a member of the Governing Body desire to discuss any item, it will be removed from the Consent Agenda and considered separately.
 - a) Approval of the minutes of the meeting of November 15, 2023
 - b) Approval of the schedule for the week November 20, 2023
 - c) Approval of the check register

- d) Approve and sign the OCB's
- e) Approve letters of support for The Guidance Center for grant funding

VII. FORMAL BOARD ACTION:

a) 2023 General Election Canvass

- **CONSIDER A MOTION TO ADJOURN AS THE BOARD OF COUNTY COMMISSIONERS AND CONVENE AS THE BOARD OF COUNTY CANVASSERS.**
- **CONSIDER A MOTION TO ACCEPT THE PROVISIONALS AS RECOMMENDED BY THE COUNTY CLERK.**
- **CONSIDER A MOTION TO CERTIFY THE 2023 GENERAL ELECTION.**
- **CONSIDER A MOTION TO ADJOURN AS THE BOARD OF COUNTY CANVASSERS AND RECONVENE AS THE BOARD OF COUNTY COMMISSIONERS.**

b) Consider a motion to approve a contract renewal with Symmetry Energy Solutions for natural gas service at the Cushing Building.

c) Consider a motion to approve an agreement with Benesch to allow them to pay Dondlinger Construction directly for repairs to Bridge F-46.

d) Consider a motion to approve Resolution 2023-31, an amended resolution revising Section 4 (a)(8) of Resolution 2023-24 to provide for the general composition of the Juvenile Corrections Advisory Board and allow for additional members as authorized by state statute.

VIII. PRESENTATIONS AND DISCUSSION ITEMS: presentations are materials of general concern where no action or vote is requested or anticipated.

IX. ADDITIONAL PUBLIC COMMENT IF NEEDED

X. ADJOURNMENT

LEAVENWORTH COUNTY COMMISSIONERS MEETING SCHEDULE

Monday, November 13, 2023

11:00 a.m. Saint Mary's Veteran's Day Pinning Ceremony
• Social Room (Second Floor of Saint Mary Hall)

Tuesday, November 14, 2023

11:30 a.m. 38th Annual Athena Awards Luncheon
• Riverfront Community Center, 123 S. Esplanade St., Leavenworth, KS

Wednesday, November 15, 2023

8:14 a.m. Register of Deeds ribbon-cutting

9:00 a.m. Leavenworth County Commission meeting
• Commission Meeting Room, 300 Walnut, Leavenworth KS

Thursday, November 16, 2023

8:00 a.m. Legislative Breakfast
• Council on Aging, 711 Marshall St., Leavenworth, KS

Friday, November 17, 2023

8:00 a.m. Northeast Kansas County Officials Annual Meeting
• Nemaha County Community Building, 1500 Community Drive, Seneca, KS

ALL SUCH OTHER BUSINESS THAT MAY COME BEFORE THE COMMISSION

ALL MEETINGS ARE OPEN TO THE PUBLIC

COMMENTS SHOULD BE OF GENERAL INTEREST OF THE PUBLIC AND SUBJECT TO THE RULES OF DECORUM

*****November 8, 2023 *****

The Board of County Commissioners met in a regular session on Wednesday, November 8, 2023. Commissioner Kaaz, Commissioner Doug Smith, Commissioner Mike Smith, Commissioner Culbertson and Commissioner Stieben are present; Also present: Mark Loughry, County Administrator; David Van Parys, Senior County Counselor; Janet Klasinski, County Clerk; Bill Noll, Infrastructure and Construction Services; John Jacobson, Planning and Zoning Director; John Richmeier, Leavenworth Times

Residents: John Matthews, Raymond Reynolds, Brendan Sheehan, Chris Kerry

PUBLIC COMMENT:

There were no public comments.

ADMINISTRATIVE BUSINESS:

Commissioner Kaaz read a proclamation recognizing Operation Green Light for veterans.

Janet Klasinski requested the chairperson to randomly select two precincts to audit in which one is USD #469 and the other is city of Leavenworth Commission. Commissioner Kaaz randomly selected Lansing Ward 3 for the school district and second precinct, sixth ward for the Leavenworth City Commission.

Mark Loughry reported the Register of Deeds will hold a ribbon-cutting ceremony on Wednesday, November 15, 2023 at 8:14 a.m.

Mr. Loughry thanked employees who participated in the health assessments.

Commissioner Culbertson indicated he has been called for jury duty next Monday and may not be able to attend the meeting on Wednesday.

A motion was made by Commissioner Culbertson and seconded by Commissioner Mike Smith to accept the consent agenda for Wednesday, November 8, 2023 as presented.

Motion passed, 5-0.

Brenden Sheehan requested approval of US Bicycle Route 55 and a letter of support.

A motion was made by Commissioner Mike Smith and seconded by Commissioner Culbertson to approve US Bicycle Route 55 through Leavenworth County and a letter of support.

Motion passed, 5-0.

Resolution 10-23-03 from the city of Tonganoxie was presented for consideration of approval for an annexation.

A motion was made by Commissioner Kaaz and seconded by Commissioner Mike Smith that the proposed annexation hinders the proper growth and development of the area.

Motion passed, 5-0.

Bill Noll requested approval of contract with SMH for design services for the high-risk rural roads project on Tonganoxie Road.

A motion was made by Commissioner Mike Smith and seconded by Commissioner Doug Smith to approve a contract with SMH for design services for the high-risk rural roads project on Tonganoxie Road.

Motion passed, 5-0.

Mr. Noll requested approval of a contract for construction with Kaaz Construction for three replacement culverts through ARPA funds.

A motion was made by Commissioner Doug Smith and seconded by Commissioner Culbertson to approve culvert replacement to the local contractor Julius Kaaz Construction for ST-59 and ST-60 and K-37.
Motion passed, 4-0, Commissioner Kaaz abstained.

Raymond Reynolds commented on a non-agenda item.

Commissioner Mike Smith will attend the LCDC annual VIP meeting on Friday and the Veteran's Day Parade on Saturday.

Commissioners Kaaz and Doug Smith attended the Council on Aging fundraiser for Meals on Wheels. She will attend the St. Mary's Veteran's Day Pinning Ceremony on Monday.

Commissioner Doug Smith will participate in the Veteran's Day Parade and the ribbon-cutting ceremony for the Register of Deeds.

Commissioner Stieben thanked everyone that ran for office.

Commissioner Culbertson attended the Easton City Council meeting.

Mr. Loughry reminded everyone the Courthouse will be closed this Friday in observance of Veteran's Day.

A motion was made by Commissioner Mike Smith and seconded by Commissioner Doug Smith to adjourn.

Motion passed, 5-0.

The Board adjourned at 10:07 a.m.

LEAVENWORTH COUNTY COMMISSIONERS MEETING SCHEDULE

Monday, November 20, 2023

Tuesday, November 21, 2023

12:00 p.m. LCPA meeting

Wednesday, November 22, 2023

9:00 a.m. Leavenworth County Commission meeting
• Commission Meeting Room, 300 Walnut, Leavenworth KS

Thursday, November 23, 2023 THE COURTHOUSE WILL BE CLOSED IN OBSERVANCE OF THANKSGIVING

Friday, November 24, 2023 THE COURTHOUSE WILL BE CLOSED IN OBSERVANCE OF THANKSGIVING

ALL SUCH OTHER BUSINESS THAT MAY COME BEFORE THE COMMISSION

ALL MEETINGS ARE OPEN TO THE PUBLIC

COMMENTS SHOULD BE OF GENERAL INTEREST OF THE PUBLIC AND SUBJECT TO THE RULES OF DECORUM

START DATE: 11/04/2023 END DATE: 11/09/2023

TYPES OF CHECKS SELECTED: * ALL TYPES

			P.O.NUMBER	CHECK#					
1061	B & W FIRE LLC	B & W FIRE LLC	337496	105459 AP	11/09/2023	3-001-5-07-208	LVS0 PATROL ANNUAL FIRE EXT IN	107.70	
773	BASEHOR FIRST	FIRST BAPTIST CHURCH OF BASEHO	337497	105460 AP	11/09/2023	3-001-5-49-341	GENERAL ELECTION POLLING PLACE	50.00	
770	BASEHOR UNITED	BASEHOR UNITED METHODIST CHURC	337498	105461 AP	11/09/2023	3-001-5-49-341	GENERAL ELECTION POLLING PLACE	50.00	
2541	BEST PLUMBING SPECIA	BEST PLUMBING SPECIALTIES,INC	337499	105462 AP	11/09/2023	3-001-5-07-357	35483 JAIL PLUMBING SUPPLIES	200.70	
2541	BEST PLUMBING SPECIA	BEST PLUMBING SPECIALTIES,INC	337499	105462 AP	11/09/2023	3-001-5-07-357	35483 JAIL PLUMBING SUPPLIES	640.16-	
2541	BEST PLUMBING SPECIA	BEST PLUMBING SPECIALTIES,INC	337499	105462 AP	11/09/2023	3-001-5-07-357	35483 JAIL PLUMBING SUPPLIES	1,644.00-	
2541	BEST PLUMBING SPECIA	BEST PLUMBING SPECIALTIES,INC	337499	105462 AP	11/09/2023	3-001-5-07-357	35483 JAIL PLUMBING SUPPLIES	188.72	
2541	BEST PLUMBING SPECIA	BEST PLUMBING SPECIALTIES,INC	337499	105462 AP	11/09/2023	3-001-5-07-357	35483 JAIL PLUMBING SUPPLIES	29.02	
2541	BEST PLUMBING SPECIA	BEST PLUMBING SPECIALTIES,INC	337499	105462 AP	11/09/2023	3-001-5-07-357	35483 JAIL PLUMBING SUPPLIES	1,317.47	
2541	BEST PLUMBING SPECIA	BEST PLUMBING SPECIALTIES,INC	337499	105462 AP	11/09/2023	3-001-5-07-357	35483 JAIL PLUMBING SUPPLIES	29.89	
2541	BEST PLUMBING SPECIA	BEST PLUMBING SPECIALTIES,INC	337499	105462 AP	11/09/2023	3-001-5-07-357	35483 JAIL PLUMBING SUPPLIES	560.50	
							*** VENDOR	2541 TOTAL	42.14
1523	BOB BARKER	BOB BARKER CO INC	337500	105463 AP	11/09/2023	3-001-5-07-359	LEAKS4 JAIL SUPPLIES	2,050.59	
1523	BOB BARKER	BOB BARKER CO INC	337500	105463 AP	11/09/2023	3-001-5-07-359	LEAKS4 JAIL SUPPLIES	1,825.50	
							*** VENDOR	1523 TOTAL	3,876.09
23537	BOUND TREE	BOUND TREE MEDICAL LLC	337501	105464 AP	11/09/2023	3-001-5-05-381	113712 FIELD SUPPLIES FOR AMBU	2,230.23	
23537	BOUND TREE	BOUND TREE MEDICAL LLC	337501	105464 AP	11/09/2023	3-001-5-05-381	113712 FIELD SUPPLIES FOR AMBU	3,746.78	
							*** VENDOR	23537 TOTAL	5,977.01
1298	BROWNELLS INC	BROWNELLS INC	337457	105436 AP	11/07/2023	3-001-5-07-356	00391455 CLEANING SUPPLIES FOR	125.86	
866	CALVARY BAPTIST CHUR	CALVARY BAPTIST CHURCH	337502	105465 AP	11/09/2023	3-001-5-49-341	GENERAL ELECTION POLLING PLACE	100.00	
25101	CANON U S	CANON U S A INC	337503	105466 AP	11/09/2023	3-001-5-19-204	18656950 DIST CT CLERKS FRONT	433.53	
24545	CDW GOVERN	CDW GOVERNMENT INC	337504	105467 AP	11/09/2023	3-001-5-18-254	3773122 SOFTWARE SUB	824.08	
22543	COMPLETE FAMILY CARE	COMPLETE FAMILY CARE	337505	105468 AP	11/09/2023	3-001-5-05-201	EMS MEDICAL DIRECTOR FEE	1,250.00	
2900	EMS OVERPAYMENT	PATIENT	337508	105471 AP	11/09/2023	3-001-5-05-290	REF PT - S/B MEDICARE WRITE OF	21.54	
86	EVERGY	EVERGY KANSAS CENTRAL INC	337459	105438 AP	11/07/2023	3-001-5-05-215	ELEC SVC EMS 9103	413.60	
86	EVERGY	EVERGY KANSAS CENTRAL INC	337509	105472 AP	11/09/2023	3-001-5-33-392	ELEC SVC 711 MARSHALL	8,553.60	
							*** VENDOR	86 TOTAL	8,967.20
1791	FIRST BAPT	FIRST BAPTIST CHURCH	337510	105473 AP	11/09/2023	3-001-5-49-341	GENERAL ELECTION POLLING PLACE	150.00	
3550	FISHER, PATTERSON	FISHER, PATTERSON, SAYLER & SMIT	337511	105474 AP	11/09/2023	3-001-5-01-230	FILE 337-38184-ADH LITIGATION	1,075.00	
3550	FISHER, PATTERSON	FISHER, PATTERSON, SAYLER & SMIT	337511	105474 AP	11/09/2023	3-001-5-01-230	FILE 337-38184-ADH LITIGATION	38.00	
							*** VENDOR	3550 TOTAL	1,113.00
243	GEOTAB	GEOTAB USA INC	337512	105475 AP	11/09/2023	3-001-5-11-253	LEAV01 OCTOBER GEOLOCATING SER	16.33	
243	GEOTAB	GEOTAB USA INC	337512	105475 AP	11/09/2023	3-001-5-31-230	LEAV01 OCTOBER GEOLOCATING SER	48.99	
243	GEOTAB	GEOTAB USA INC	337512	105475 AP	11/09/2023	3-001-5-41-271	LEAV01 OCTOBER GEOLOCATING SER	81.65	
							*** VENDOR	243 TOTAL	146.97
120	GRENIER AUTOWORKS	ALFRED GRENIER II	337513	105476 AP	11/09/2023	3-001-5-07-213	LVS0 UPFIT NEW UNIT 111	2,368.50	
2464	HEARTLAND METRO TACT	HEARTLAND METRO TACTICAL OFFIC	337461	105440 AP	11/07/2023	3-001-5-07-202	HOTA BASIC SNIPER COURSE	500.00	
26830	HIGH PRAIR	HIGH PRAIRIE CHURCH	337514	105477 AP	11/09/2023	3-001-5-49-341	GENERAL ELECTION POLLING PLACE	50.00	
8416	IRON MOUNTAIN	IRON MOUNTAIN INC	337515	105478 AP	11/09/2023	3-001-5-11-208	RSVP8/COUNTY ATTORNEY	26.00	
3030	ISG TECHNOLOGY	ISG TECHNOLOGY	337464	105443 AP	11/07/2023	3-001-5-18-220	PROF SVCS	318.75	
99	JUROR								

warrants by vendor

TYPES OF CHECKS SELECTED: * ALL TYPES

P.O.NUMBER CHECK#

99 JUROR

warrants by vendor

START DATE: 11/04/2023 END DATE: 11/09/2023

TYPES OF CHECKS SELECTED: * ALL TYPES

		P.O.NUMBER	CHECK#							
99	JUROR									
							*** VENDOR	99 TOTAL	3,295.82	
6636	KANSAS GAS	KANSAS GAS SERVICE	337465	105444 AP	11/07/2023	3-001-5-05-215	512142220 2006970 09 GAS SERVI	94.91		
6636	KANSAS GAS	KANSAS GAS SERVICE	337465	105444 AP	11/07/2023	3-001-5-05-215	510263944 1556921 09 GAS SERVI	52.46		
6636	KANSAS GAS	KANSAS GAS SERVICE	337576	105539 AP	11/09/2023	3-001-5-05-215	510614745 2015657 27 GAS TRANS	84.92		
6636	KANSAS GAS	KANSAS GAS SERVICE	337576	105539 AP	11/09/2023	3-001-5-14-220	510614745 1631910 36 GAS SERVI	84.31		
							*** VENDOR	6636 TOTAL	316.60	
4364	KLOTZ AGEN	THE KLOTZ AGENCY INC	337577	105540 AP	11/09/2023	3-001-5-11-203	NOTARY PUBLIC BOND-JORDAN ROBB	75.00		
19903	LANGUAGE L	LANGUAGE LINE SERVICES INC	337578	105541 AP	11/09/2023	3-001-5-19-221	9020533027 DIST CT INTERPRETER	162.68		
1466	LEAV BAPTIST	LEAVENWORTH BAPTIST CHURCH	337579	105542 AP	11/09/2023	3-001-5-49-341	GENERAL ELECTION POLLING PLACE	100.00		
975	LEAV LANSI	LEAVENWORTH/LANSING CHAMBER	337581	105544 AP	11/09/2023	3-001-5-01-205	ATHENA AWARDS LUNCHEON - COMM	40.00		
4755	LEAV PAPER	LEAVENWORTH PAPER AND OFFICE S	337582	105545 AP	11/09/2023	3-001-5-19-301	DIST CT FOLDERS, FASTERNERS	253.00		
4755	LEAV PAPER	LEAVENWORTH PAPER AND OFFICE S	337582	105545 AP	11/09/2023	3-001-5-19-301	DIST CT CLERK INK STAMPS X4	110.00		
4755	LEAV PAPER	LEAVENWORTH PAPER AND OFFICE S	337582	105545 AP	11/09/2023	3-001-5-19-301	DIST CT CLERK OFFICE SUPPLIES	3,307.84		
4755	LEAV PAPER	LEAVENWORTH PAPER AND OFFICE S	337582	105545 AP	11/09/2023	3-001-5-19-301	DIST COURT RECEIPT BOOKS X4	22.60		
							*** VENDOR	4755 TOTAL	3,693.44	
537	LEAV TIMES	CHERRYROAD MEDIA INC	337583	105546 AP	11/09/2023	3-001-5-03-218	21275 PUBLICATION - DELINQUENT	430.17		

warrants by vendor

START DATE: 11/04/2023 END DATE: 11/09/2023

TYPES OF CHECKS SELECTED: * ALL TYPES

			P.O.NUMBER	CHECK#					
537	LEAV TIMES	CHERRYROAD MEDIA INC	337583	105546 AP	11/09/2023	3-001-5-06-218	21250 RESOLUTION, LEGAL NOTICE	38.94	
537	LEAV TIMES	CHERRYROAD MEDIA INC	337583	105546 AP	11/09/2023	3-001-5-06-218	21250 RESOLUTION, LEGAL NOTICE	6.39	
537	LEAV TIMES	CHERRYROAD MEDIA INC	337583	105546 AP	11/09/2023	3-001-5-06-218	21250 RESOLUTION, LEGAL NOTICE	9.99	
537	LEAV TIMES	CHERRYROAD MEDIA INC	337583	105546 AP	11/09/2023	3-001-5-06-218	21250 RESOLUTION, LEGAL NOTICE	10.58	
537	LEAV TIMES	CHERRYROAD MEDIA INC	337583	105546 AP	11/09/2023	3-001-5-06-218	21250 RESOLUTION, LEGAL NOTICE	12.78	
537	LEAV TIMES	CHERRYROAD MEDIA INC	337583	105546 AP	11/09/2023	3-001-5-49-341	21272 PUBLICATION OF CANVASS N	4.39	
							*** VENDOR	537 TOTAL	513.24
10219	LINWOOD DE	LINWOOD COMMUNITY DEVELOPMENT	337585	105548 AP	11/09/2023	3-001-5-49-341	GENERAL ELECTION POLLING PLACE	150.00	
17244	MARLOW WHI	MARLOW WHITE UNIFORM CO	337586	105549 AP	11/09/2023	3-001-5-07-350	SHERIFF UNIFORM	152.45	
2419	MCKESSON MEDICAL SUR	MCKESSON MEDICAL SURGICAL	337587	105550 AP	11/09/2023	3-001-5-07-219	MEDICAL SUPPLIES, INMATES	4.91	
2419	MCKESSON MEDICAL SUR	MCKESSON MEDICAL SURGICAL	337587	105550 AP	11/09/2023	3-001-5-07-219	4227555 SHERIFF INMATE HEALTH	5.89	
2419	MCKESSON MEDICAL SUR	MCKESSON MEDICAL SURGICAL	337587	105550 AP	11/09/2023	3-001-5-07-219	4227555 SHERIFF INMATE HEALTH	24.73	
							*** VENDOR	2419 TOTAL	35.53
2059	MIDWEST OFFICE TECH	MIDWEST OFFICE TECHNOLOGY INC	337588	105551 AP	11/09/2023	3-001-5-05-283	OPK597_K COPIER- EMS	305.41	
3	OTHER COUNTY OFFICE	NEMAHA COUNTYOFFICE	337592	105556 AP	11/09/2023	3-001-5-01-202	2023 NORTHEAST KANSAS OFFICIAL	20.00	
3	OTHER COUNTY OFFICE	NEMAHA COUNTYOFFICE	337592	105556 AP	11/09/2023	3-001-5-02-203	2023 NORTHEAST KANSAS OFFICIAL	20.00	
3	OTHER COUNTY OFFICE	NEMAHA COUNTYOFFICE	337592	105556 AP	11/09/2023	3-001-5-04-202	2023 NORTHEAST KANSAS OFFICIAL	20.00	
3	OTHER COUNTY OFFICE	AYETTE COUNTY SHERIFFS OFFICE	337467	105446 AP	11/07/2023	3-001-5-07-219	REIMB FOR RX - INMATE HELD FOR	840.35	
3	OTHER COUNTY OFFICE	NEMAHA COUNTYOFFICE	337592	105556 AP	11/09/2023	3-001-5-09-202	2023 NORTHEAST KANSAS OFFICIAL	20.00	
3	OTHER COUNTY OFFICE	NEMAHA COUNTYOFFICE	337592	105556 AP	11/09/2023	3-001-5-41-211	2023 NORTHEAST KANSAS OFFICIAL	20.00	
							*** VENDOR	3 TOTAL	940.35
2612	QUALITY REPORTING	QUALITY REPORTING	337593	105557 AP	11/09/2023	3-001-5-19-251	COURT REPORTING SVC 10/30 & 10	672.80	
7098	QUILL CORP	QUILL CORP	337594	105558 AP	11/09/2023	3-001-5-01-301	9686154 BOCC SUPPLIES	65.96	
7098	QUILL CORP	QUILL CORP	337594	105558 AP	11/09/2023	3-001-5-07-301	8333027 LVSO OFFICE SUPPLIES	74.85	
7098	QUILL CORP	QUILL CORP	337594	105558 AP	11/09/2023	3-001-5-28-301	5643954 OFFICE SUPPLIES	35.38	
7098	QUILL CORP	QUILL CORP	337594	105558 AP	11/09/2023	3-001-5-28-301	5643954 OFFICE SUPPLIES	280.98	
							*** VENDOR	7098 TOTAL	457.17
21567	RENO TOWN	RENO TOWNSHIP FIRE DEPT	337595	105559 AP	11/09/2023	3-001-5-49-341	GENERAL ELECTION POLLING PLACE	60.00	
14745	RISEN SAVIOR LUTHERA	RISEN SAVIOR LUTHERAN CHURCH	337596	105560 AP	11/09/2023	3-001-5-49-341	GENERAL ELECTION POLLING PLACE	50.00	
1799	SACRED HEA	SACRED HEART CHURCH	337597	105561 AP	11/09/2023	3-001-5-49-341	GENERAL ELECTION POLLING PLACE	50.00	
2615	SACRED HEART	SACRED HEART-ST. CASIMIR PARIS	337598	105562 AP	11/09/2023	3-001-5-49-341	GENERAL ELECTION POLLING PLACE	100.00	
11608	ST FRANCIS	ST FRANCIS DE SALES CATHOLIC	337599	105563 AP	11/09/2023	3-001-5-49-341	GENERAL ELECTION POLLING PLACE	100.00	
1794	ST LAWRENC	ST LAWRENCE HALL	337600	105564 AP	11/09/2023	3-001-5-49-341	GENERAL ELECTION POLLING PLACE	100.00	
518	SUNSET	SUNSET LAW ENFORCEMENT LLC	337469	105448 AP	11/07/2023	3-001-5-07-356	0660482 AMMUNITION	5,366.00	
4445	T MOBILE	T-MOBILE USA, INC	337470	105449 AP	11/07/2023	3-001-5-05-210	EMS WIRELESS SERVICES	446.59	
829	THOMSON REUTERS	THOMSON REUTERS - WEST	337602	105566 AP	11/09/2023	3-001-5-09-209	1000090351 KS L&P V4-6	359.00	
829	THOMSON REUTERS	THOMSON REUTERS - WEST	337602	105566 AP	11/09/2023	3-001-5-19-301	1000588228 LS L&P CIVPRO 5TH X	678.00	
							*** VENDOR	829 TOTAL	1,037.00
521	TRINITY LU	TRINITY LUTHERAN CHURCH	337603	105567 AP	11/09/2023	3-001-5-49-341	GENERAL ELECTION POLLING PLACE	100.00	
2	WATER DEPT	WATER DEPT	337605	105569 AP	11/09/2023	3-001-5-05-215	WATER SVC EMS 9101	82.64	
2	WATER DEPT	WATER DEPT	337605	105569 AP	11/09/2023	3-001-5-05-215	WATER SVC EMS ADMIN	55.95	
2	WATER DEPT	WATER DEPT	337605	105569 AP	11/09/2023	3-001-5-14-220	WATER SVC COURTHOUSE	1,219.76	
2	WATER DEPT	WATER DEPT	337605	105569 AP	11/09/2023	3-001-5-32-392	WATER SERVICE JUSTICE CENTER	3,497.57	
2	WATER DEPT	WATER DEPT	337605	105569 AP	11/09/2023	3-001-5-33-392	WATER SVC CUSHING BLDG 2 METER	99.17	
2	WATER DEPT	WATER DEPT	337605	105569 AP	11/09/2023	3-001-5-33-392	WATER SVC CUSHING BLDG 2 METER	439.58	
							*** VENDOR	2 TOTAL	5,394.67
865	WEST HAVEN BAPTIST	WEST HAVEN BAPTIST CHURCH	337606	105570 AP	11/09/2023	3-001-5-49-341	GENERAL ELECTION POLLING PLACE	50.00	
276	WEX	WEX BANK	337613	74	11/09/2023	3-001-5-14-331	0496-00-668063-1 FUEL TO 10.23	10,353.22	
276	WEX	WEX BANK	337613	74	11/09/2023	3-001-5-14-332	0496-00-668063-1 FUEL TO 10.23	6,480.12	
276	WEX	WEX BANK	337613	74	11/09/2023	3-001-5-14-334	0496-00-668063-1 FUEL TO 10.23	472.07	
276	WEX	WEX BANK	337613	74	11/09/2023	3-001-5-14-335	0496-00-668063-1 FUEL TO 10.23	128.70	
276	WEX	WEX BANK	337613	74	11/09/2023	3-001-5-14-901	0496-00-668063-1 FUEL TO 10.23	187.48-	

START DATE: 11/04/2023 END DATE: 11/09/2023

TYPES OF CHECKS SELECTED: * ALL TYPES

			P.O.NUMBER	CHECK#					
276	WEX	WEX BANK	337613	74	11/09/2023	3-001-5-14-901	0496-00-668063-1 FUEL TO 10.23	119.93-	
							*** VENDOR	276 TOTAL	17,126.70
100	WITNESS LIST						*** VENDOR	100 TOTAL	799.03
							TOTAL FUND 001		68,188.85
22543	COMPLETE FAMILY CARE	COMPLETE FAMILY CARE	337505	105468 AP	11/09/2023	3-108-5-00-280	HEALTH DEPT NOV MEDICAL FEES	1,200.00	
22543	COMPLETE FAMILY CARE	COMPLETE FAMILY CARE	337505	105468 AP	11/09/2023	3-108-5-00-280	HEALTH DEPT NOV MEDICAL FEES	300.00	
							*** VENDOR	22543 TOTAL	1,500.00
1629	KU PHYSICIANS	KANSAS UNIVERSITY PHYSICIANS I	337466	105445 AP	11/07/2023	3-108-5-00-280	C-10180 PRENATAL CLINICAL SERV	1,800.00	
1629	KU PHYSICIANS	KANSAS UNIVERSITY PHYSICIANS I	337466	105445 AP	11/07/2023	3-108-5-00-280	C-10180 PRENATAL CLINICAL SERV	1,800.00	
							*** VENDOR	1629 TOTAL	3,600.00
2	WATER DEPT	WATER DEPT	337605	105569 AP	11/09/2023	3-108-5-00-219	WATER SVC WIC/HEALTH DEPT	41.97	
2	WATER DEPT	WATER DEPT	337605	105569 AP	11/09/2023	3-108-5-00-606	WATER SVC WIC/HEALTH DEPT	13.98	
							*** VENDOR	2 TOTAL	55.95
276	WEX	WEX BANK	337613	74	11/09/2023	3-108-5-00-304	FUEL TO 10.23	97.75	
276	WEX	WEX BANK	337613	74	11/09/2023	3-108-5-00-606	FUEL TO 10.23	20.95	
276	WEX	WEX BANK	337613	74	11/09/2023	3-108-5-00-610	FUEL TO 10.23	20.95	
							*** VENDOR	276 TOTAL	139.65
							TOTAL FUND 108		5,295.60
24545	CDW GOVERN	CDW GOVERNMENT INC	337504	105467 AP	11/09/2023	3-115-5-00-409	3773122 UPS BATTERIES	296.59	
243	GEOTAB	GEOTAB USA INC	337512	105475 AP	11/09/2023	3-115-5-00-415	LEAV01 OCTOBER GEOLOCATING SER	16.33	
243	GEOTAB	GEOTAB USA INC	337512	105475 AP	11/09/2023	3-115-5-00-423	LEAV01 OCTOBER GEOLOCATING SER	114.31	
243	GEOTAB	GEOTAB USA INC	337512	105475 AP	11/09/2023	3-115-5-00-434	LEAV01 OCTOBER GEOLOCATING SER	538.89	
243	GEOTAB	GEOTAB USA INC	337512	105475 AP	11/09/2023	3-115-5-00-436	LEAV01 OCTOBER GEOLOCATING SER	207.57	
							*** VENDOR	243 TOTAL	877.10
							TOTAL FUND 115		1,173.69
3998	DREXEL TEC	DREXEL TECHNOLOGIES INC	337507	105470 AP	11/09/2023	3-119-5-00-252	24896 SERVICE CONTRACTS JUN,JU	115.00	

warrants by vendor

TYPES OF CHECKS SELECTED: * ALL TYPES

				P.O.NUMBER	CHECK#					
3998	DREXEL TEC	DREXEL TECHNOLOGIES INC	337507	105470 AP	11/09/2023	3-119-5-00-252	24896 SERVICE CONTRACTS JUN,JU	115.00		
3998	DREXEL TEC	DREXEL TECHNOLOGIES INC	337507	105470 AP	11/09/2023	3-119-5-00-252	24896 SERVICE CONTRACTS JUN,JU	115.00		
								*** VENDOR	3998 TOTAL	345.00
1768	VITAL RECORDS	VITAL RECORDS HOLDING, LLC	337604	105568 AP	11/09/2023	3-119-5-00-252	38014 ANNUAL STORAGE/MAINT - 1	46.25		
1768	VITAL RECORDS	VITAL RECORDS HOLDING, LLC	337604	105568 AP	11/09/2023	3-119-5-00-252	38014 ANNUAL STORAGE/MAINT - 1	867.50		
1768	VITAL RECORDS	VITAL RECORDS HOLDING, LLC	337604	105568 AP	11/09/2023	3-119-5-00-252	38014 ANNUAL STORAGE/MAINT - 1	152.29-		
								*** VENDOR	1768 TOTAL	761.46
								TOTAL FUND 119		1,106.46

24562	JJA	KDOC:DIV OF JUVENILE SERVICES	337516	105479 AP	11/09/2023	3-123-5-00-301	JCPY FY23 UNSPENT FUNDS RETURN	25,489.84		
								TOTAL FUND 123		25,489.84

20588	ADVANTAGE	ADVANTAGE PRINTING	337494	105457 AP	11/09/2023	3-126-5-00-301	ACCT 52 COMM CORR APPOINTMENT	62.50		
20588	ADVANTAGE	ADVANTAGE PRINTING	337494	105457 AP	11/09/2023	3-126-5-00-301	ACCT 52 COMM CORR APPOINTMENT	70.00		
								*** VENDOR	20588 TOTAL	132.50
1220	CULLIGAN OF GREATER	CULLIGAN OF GREATER KANSAS CIT	337458	105437 AP	11/07/2023	3-126-5-00-225	1220762 WATER/COOLER RENTAL	42.00		
243	GEOTAB	GEOTAB USA INC	337512	105475 AP	11/09/2023	3-126-5-00-221	LEAV01 OCTOBER GEOLOCATING SER	16.33		
2505	INTRINSIC INTERVENTI	INTRINSIC INTERVENTIONS	337463	105442 AP	11/07/2023	3-126-5-00-226	SMART SCREEN UA TEST CUPS	1,273.00		
113	SUMNERONE INC	SUMNERONE INC	337601	105565 AP	11/09/2023	3-126-5-00-321	50COL COPIES - ADT COMM CORR	130.25		
276	WEX	WEX BANK	337613	74	11/09/2023	3-126-5-00-221	FUEL TO 10.23	35.49		
								TOTAL FUND 126		1,629.57

276	WEX	WEX BANK	337613	74	11/09/2023	3-127-5-00-3	CORRECTION TO SEPT PURCHASE OR	.31-		
								TOTAL FUND 127		.31

461	LEAV CO CO	LEAV CO COOP	337580	105543 AP	11/09/2023	3-133-5-00-304	11-5 FLUIDS/LUBES, FUEL	40,644.36		
461	LEAV CO CO	LEAV CO COOP	337580	105543 AP	11/09/2023	3-133-5-00-310	11-5 FLUIDS/LUBES, FUEL	1,164.40		
								*** VENDOR	461 TOTAL	41,808.76
11799	O'REILLY A	O'REILLY AUTOMOTIVE	337590	105554 AP	11/09/2023	3-133-5-00-309	11-8 19615 FILTRS, ABSORBENT,T	1.35		
11799	O'REILLY A	O'REILLY AUTOMOTIVE	337590	105554 AP	11/09/2023	3-133-5-00-309	11-8 19615 FILTRS, ABSORBENT,T	1.35-		
11799	O'REILLY A	O'REILLY AUTOMOTIVE	337590	105554 AP	11/09/2023	3-133-5-00-309	11-6 19615 FILTERS, PLUGS, BRA	84.00		
11799	O'REILLY A	O'REILLY AUTOMOTIVE	337590	105554 AP	11/09/2023	3-133-5-00-310	11-7 19615 FITLERS, FLUIDS, MI	161.64		
11799	O'REILLY A	O'REILLY AUTOMOTIVE	337590	105554 AP	11/09/2023	3-133-5-00-310	11-7 19615 FITLERS, FLUIDS, MI	116.82		
11799	O'REILLY A	O'REILLY AUTOMOTIVE	337590	105554 AP	11/09/2023	3-133-5-00-310	11-7 19615 FITLERS, FLUIDS, MI	36.00-		
11799	O'REILLY A	O'REILLY AUTOMOTIVE	337590	105554 AP	11/09/2023	3-133-5-00-310	11-6 19615 FILTERS, PLUGS, BRA	134.95		
11799	O'REILLY A	O'REILLY AUTOMOTIVE	337590	105554 AP	11/09/2023	3-133-5-00-312	11-8 19615 FILTRS, ABSORBENT,T	119.90		
11799	O'REILLY A	O'REILLY AUTOMOTIVE	337590	105554 AP	11/09/2023	3-133-5-00-312	11-7 19615 FITLERS, FLUIDS, MI	21.59		
11799	O'REILLY A	O'REILLY AUTOMOTIVE	337590	105554 AP	11/09/2023	3-133-5-00-312	11-7 19615 FITLERS, FLUIDS, MI	7.49		
11799	O'REILLY A	O'REILLY AUTOMOTIVE	337590	105554 AP	11/09/2023	3-133-5-00-312	11-7 19615 FITLERS, FLUIDS, MI	20.18		
11799	O'REILLY A	O'REILLY AUTOMOTIVE	337590	105554 AP	11/09/2023	3-133-5-00-360	11-8 19615 FILTRS, ABSORBENT,T	18.71		
11799	O'REILLY A	O'REILLY AUTOMOTIVE	337590	105554 AP	11/09/2023	3-133-5-00-360	11-8 19615 FILTRS, ABSORBENT,T	73.15		
11799	O'REILLY A	O'REILLY AUTOMOTIVE	337590	105554 AP	11/09/2023	3-133-5-00-360	11-8 19615 FILTRS, ABSORBENT,T	17.16		
11799	O'REILLY A	O'REILLY AUTOMOTIVE	337590	105554 AP	11/09/2023	3-133-5-00-360	11-8 19615 FILTRS, ABSORBENT,T	25.12		
11799	O'REILLY A	O'REILLY AUTOMOTIVE	337590	105554 AP	11/09/2023	3-133-5-00-360	11-8 19615 FILTRS, ABSORBENT,T	4.75		
11799	O'REILLY A	O'REILLY AUTOMOTIVE	337590	105554 AP	11/09/2023	3-133-5-00-360	11-7 19615 FITLERS, FLUIDS, MI	318.38		
11799	O'REILLY A	O'REILLY AUTOMOTIVE	337590	105554 AP	11/09/2023	3-133-5-00-360	11-7 19615 FITLERS, FLUIDS, MI	42.36		
11799	O'REILLY A	O'REILLY AUTOMOTIVE	337590	105554 AP	11/09/2023	3-133-5-00-360	11-7 19615 FITLERS, FLUIDS, MI	106.02		
11799	O'REILLY A	O'REILLY AUTOMOTIVE	337590	105554 AP	11/09/2023	3-133-5-00-360	11-7 19615 FITLERS, FLUIDS, MI	36.98-		
11799	O'REILLY A	O'REILLY AUTOMOTIVE	337590	105554 AP	11/09/2023	3-133-5-00-360	11-7 19615 FITLERS, FLUIDS, MI	35.55		
11799	O'REILLY A	O'REILLY AUTOMOTIVE	337590	105554 AP	11/09/2023	3-133-5-00-360	11-7 19615 FITLERS, FLUIDS, MI	91.55		
11799	O'REILLY A	O'REILLY AUTOMOTIVE	337590	105554 AP	11/09/2023	3-133-5-00-360	11-7 19615 FITLERS, FLUIDS, MI	105.00		
11799	O'REILLY A	O'REILLY AUTOMOTIVE	337590	105554 AP	11/09/2023	3-133-5-00-360	11-7 19615 FITLERS, FLUIDS, MI	49.79		

TYPES OF CHECKS SELECTED: * ALL TYPES

			P.O. NUMBER	CHECK#						
11799	O'REILLY A	O'REILLY AUTOMOTIVE	337590	105554 AP	11/09/2023	3-133-5-00-360	11-7 19615 FITLERS, FLUIDS, MI	129.99		
11799	O'REILLY A	O'REILLY AUTOMOTIVE	337590	105554 AP	11/09/2023	3-133-5-00-360	11-7 19615 FITLERS, FLUIDS, MI	146.30		
11799	O'REILLY A	O'REILLY AUTOMOTIVE	337590	105554 AP	11/09/2023	3-133-5-00-360	11-7 19615 FITLERS, FLUIDS, MI	50.39		
11799	O'REILLY A	O'REILLY AUTOMOTIVE	337590	105554 AP	11/09/2023	3-133-5-00-360	11-7 19615 FITLERS, FLUIDS, MI	28.04		
11799	O'REILLY A	O'REILLY AUTOMOTIVE	337590	105554 AP	11/09/2023	3-133-5-00-360	11-7 19615 FITLERS, FLUIDS, MI	51.17		
11799	O'REILLY A	O'REILLY AUTOMOTIVE	337590	105554 AP	11/09/2023	3-133-5-00-360	11-7 19615 FITLERS, FLUIDS, MI	26.40		
11799	O'REILLY A	O'REILLY AUTOMOTIVE	337590	105554 AP	11/09/2023	3-133-5-00-360	11-6 19615 FILTERS, PLUGS, BRA	73.15		
11799	O'REILLY A	O'REILLY AUTOMOTIVE	337590	105554 AP	11/09/2023	3-133-5-00-360	11-6 19615 FILTERS, PLUGS, BRA	103.67		
11799	O'REILLY A	O'REILLY AUTOMOTIVE	337590	105554 AP	11/09/2023	3-133-5-00-360	11-6 19615 FILTERS, PLUGS, BRA	94.00		
11799	O'REILLY A	O'REILLY AUTOMOTIVE	337590	105554 AP	11/09/2023	3-133-5-00-360	11-6 19615 FILTERS, PLUGS, BRA	55.16		
11799	O'REILLY A	O'REILLY AUTOMOTIVE	337590	105554 AP	11/09/2023	3-133-5-00-360	11-6 19615 FILTERS, PLUGS, BRA	17.98		
11799	O'REILLY A	O'REILLY AUTOMOTIVE	337590	105554 AP	11/09/2023	3-133-5-00-360	11-6 19615 FILTERS, PLUGS, BRA	56.80		
11799	O'REILLY A	O'REILLY AUTOMOTIVE	337590	105554 AP	11/09/2023	3-133-5-00-360	11-6 19615 FILTERS, PLUGS, BRA	41.83		
11799	O'REILLY A	O'REILLY AUTOMOTIVE	337590	105554 AP	11/09/2023	3-133-5-00-360	11-6 19615 FILTERS, PLUGS, BRA	30.74		
11799	O'REILLY A	O'REILLY AUTOMOTIVE	337590	105554 AP	11/09/2023	3-133-5-00-360	11-6 19615 FILTERS, PLUGS, BRA	249.10		
11799	O'REILLY A	O'REILLY AUTOMOTIVE	337590	105554 AP	11/09/2023	3-133-5-00-360	11-6 19615 FILTERS, PLUGS, BRA	27.95		
11799	O'REILLY A	O'REILLY AUTOMOTIVE	337590	105554 AP	11/09/2023	3-133-5-00-360	11-6 19615 FILTERS, PLUGS, BRA	36.98		
11799	O'REILLY A	O'REILLY AUTOMOTIVE	337590	105554 AP	11/09/2023	3-133-5-00-360	11-6 19615 FILTERS, PLUGS, BRA	12.10		
11799	O'REILLY A	O'REILLY AUTOMOTIVE	337590	105554 AP	11/09/2023	3-133-5-00-360	11-6 19615 FILTERS, PLUGS, BRA	30.80		
11799	O'REILLY A	O'REILLY AUTOMOTIVE	337590	105554 AP	11/09/2023	3-133-5-00-360	11-6 19615 FILTERS, PLUGS, BRA	50.16		
11799	O'REILLY A	O'REILLY AUTOMOTIVE	337590	105554 AP	11/09/2023	3-133-5-00-360	11-6 19615 FILTERS, PLUGS, BRA	382.56		
11799	O'REILLY A	O'REILLY AUTOMOTIVE	337590	105554 AP	11/09/2023	3-133-5-00-360	11-6 19615 FILTERS, PLUGS, BRA	226.63		
11799	O'REILLY A	O'REILLY AUTOMOTIVE	337590	105554 AP	11/09/2023	3-133-5-00-360	11-6 19615 FILTERS, PLUGS, BRA	124.72		
11799	O'REILLY A	O'REILLY AUTOMOTIVE	337590	105554 AP	11/09/2023	3-133-5-00-360	11-6 19615 FILTERS, PLUGS, BRA	10.99		
11799	O'REILLY A	O'REILLY AUTOMOTIVE	337590	105554 AP	11/09/2023	3-133-5-00-360	11-6 19615 FILTERS, PLUGS, BRA	207.24		
11799	O'REILLY A	O'REILLY AUTOMOTIVE	337590	105554 AP	11/09/2023	3-133-5-00-365	11-7 19615 FITLERS, FLUIDS, MI	4.49		
11799	O'REILLY A	O'REILLY AUTOMOTIVE	337590	105554 AP	11/09/2023	3-133-5-00-365	11-7 19615 FITLERS, FLUIDS, MI	13.99		
11799	O'REILLY A	O'REILLY AUTOMOTIVE	337590	105554 AP	11/09/2023	3-133-5-00-365	11-6 19615 FILTERS, PLUGS, BRA	13.99		
								*** VENDOR	11799 TOTAL	3,562.47
3	OTHER COUNTY OFFICE	NEMAHA COUNTY	337591	105555 AP	11/09/2023	3-133-5-00-201	2023 NORTHEAST KANSAS OFFICIAL	20.00		
3	OTHER COUNTY OFFICE	NEMAHA COUNTY	337591	105555 AP	11/09/2023	3-133-5-00-201	2023 NORTHEAST KANSAS OFFICIAL	20.00		
3	OTHER COUNTY OFFICE	NEMAHA COUNTY	337591	105555 AP	11/09/2023	3-133-5-00-201	2023 NORTHEAST KANSAS OFFICIAL	20.00		
								*** VENDOR	3 TOTAL	60.00
276	WEX	WEX BANK	337613	74	11/09/2023	3-133-5-00-304	11-1 FUEL TO 10.23	61.34		
								TOTAL FUND 133		45,492.57

20588	ADVANTAGE	ADVANTAGE PRINTING	337494	105457 AP	11/09/2023	3-136-5-00-301	ACCT 52 COMM CORR APPOINTMENT	44.17		
20588	ADVANTAGE	ADVANTAGE PRINTING	337494	105457 AP	11/09/2023	3-136-5-00-321	ACCT 52 COMM CORR APPOINTMENT	44.17		
20588	ADVANTAGE	ADVANTAGE PRINTING	337494	105457 AP	11/09/2023	3-136-5-00-341	ACCT 52 COMM CORR APPOINTMENT	44.16		
								*** VENDOR	20588 TOTAL	132.50
1220	CULLIGAN OF GREATER	CULLIGAN OF GREATER KANSAS CIT	337458	105437 AP	11/07/2023	3-136-5-00-203	1274542 WATER/COOLER SERVICE	21.00		
1220	CULLIGAN OF GREATER	CULLIGAN OF GREATER KANSAS CIT	337458	105437 AP	11/07/2023	3-136-5-00-223	1274542 WATER/COOLER SERVICE	21.00		
								*** VENDOR	1220 TOTAL	42.00
243	GEOTAB	GEOTAB USA INC	337512	105475 AP	11/09/2023	3-136-5-00-221	LEAV01 OCTOBER GEOLOCATING SER	32.66		
113	SUMNERONE INC	SUMNERONE INC	337601	105565 AP	11/09/2023	3-136-5-00-223	5OULC08 COIES JUV COMM CORR	16.98		
113	SUMNERONE INC	SUMNERONE INC	337601	105565 AP	11/09/2023	3-136-5-00-243	5OULC08 COIES JUV COMM CORR	16.99		
113	SUMNERONE INC	SUMNERONE INC	337601	105565 AP	11/09/2023	3-136-5-00-301	5OULC08 COIES JUV COMM CORR	16.98		
								*** VENDOR	113 TOTAL	50.95
276	WEX	WEX BANK	337613	74	11/09/2023	3-136-5-00-208	FUEL TO 10.23	17.74		
276	WEX	WEX BANK	337613	74	11/09/2023	3-136-5-00-221	FUEL TO 10.23	17.75		
								*** VENDOR	276 TOTAL	35.49
								TOTAL FUND 136		293.60

TYPES OF CHECKS SELECTED: * ALL TYPES

		P.O.NUMBER	CHECK#							
461	LEAV CO CO	LEAV CO COOP	337580	105543 AP	11/09/2023	3-137-5-00-304	11-1 DYED DIESEL	17,621.50		
11799	O'REILLY A	O'REILLY AUTOMOTIVE	337590	105554 AP	11/09/2023	3-137-5-00-320	11-2 19615 FILTERS, ITTINGS, S	24.09		
11799	O'REILLY A	O'REILLY AUTOMOTIVE	337590	105554 AP	11/09/2023	3-137-5-00-320	11-2 19615 FILTERS, ITTINGS, S	149.88		
11799	O'REILLY A	O'REILLY AUTOMOTIVE	337590	105554 AP	11/09/2023	3-137-5-00-320	11-2 19615 FILTERS, ITTINGS, S	183.53		
11799	O'REILLY A	O'REILLY AUTOMOTIVE	337590	105554 AP	11/09/2023	3-137-5-00-320	11-2 19615 FILTERS, ITTINGS, S	30.08		
11799	O'REILLY A	O'REILLY AUTOMOTIVE	337590	105554 AP	11/09/2023	3-137-5-00-320	11-2 19615 FILTERS, ITTINGS, S	22.97		
11799	O'REILLY A	O'REILLY AUTOMOTIVE	337590	105554 AP	11/09/2023	3-137-5-00-320	11-2 19615 FILTERS, ITTINGS, S	15.04		
11799	O'REILLY A	O'REILLY AUTOMOTIVE	337590	105554 AP	11/09/2023	3-137-5-00-320	11-2 19615 FILTERS, ITTINGS, S	8.99		
11799	O'REILLY A	O'REILLY AUTOMOTIVE	337590	105554 AP	11/09/2023	3-137-5-00-320	11-2 19615 FILTERS, ITTINGS, S	13.98		
11799	O'REILLY A	O'REILLY AUTOMOTIVE	337590	105554 AP	11/09/2023	3-137-5-00-320	11-2 19615 FILTERS, ITTINGS, S	175.13		
11799	O'REILLY A	O'REILLY AUTOMOTIVE	337590	105554 AP	11/09/2023	3-137-5-00-320	11-2 19615 FILTERS, ITTINGS, S	18.57		
11799	O'REILLY A	O'REILLY AUTOMOTIVE	337590	105554 AP	11/09/2023	3-137-5-00-320	11-2 19615 FILTERS, ITTINGS, S	336.51		
11799	O'REILLY A	O'REILLY AUTOMOTIVE	337590	105554 AP	11/09/2023	3-137-5-00-320	11-2 19615 FILTERS, ITTINGS, S	560.13		
								*** VENDOR	11799 TOTAL	1,492.96
								TOTAL FUND 137		19,114.46
24562	JJA	KDOC:DIV OF JUVENILE SERVICES	337516	105479 AP	11/09/2023	3-138-5-00-227	JCAB FY23 UNSPENT FUNDS RETURN	11,675.33		
								TOTAL FUND 138		11,675.33
626	ADA AUCTION	ADA AUCTION MERCHANDISE SOURCE	337493	105456 AP	11/09/2023	3-145-5-00-746	TRAVIS KELCE HELMET FOR FUNDRA	500.00		
770	BASEHOR UNITED	BASEHOR UNITED METHODIST CHURC	337456	105435 AP	11/07/2023	3-145-5-00-246	UTILITY STIPEND - BASEHOR NUTR	136.00		
770	BASEHOR UNITED	BASEHOR UNITED METHODIST CHURC	337456	105435 AP	11/07/2023	3-145-5-00-246	UTILITY STIPEND - BASEHOR NUTR	136.00		
770	BASEHOR UNITED	BASEHOR UNITED METHODIST CHURC	337456	105435 AP	11/07/2023	3-145-5-05-202	UTILITY STIPEND - BASEHOR NUTR	56.00		
770	BASEHOR UNITED	BASEHOR UNITED METHODIST CHURC	337456	105435 AP	11/07/2023	3-145-5-05-202	UTILITY STIPEND - BASEHOR NUTR	56.00		
770	BASEHOR UNITED	BASEHOR UNITED METHODIST CHURC	337456	105435 AP	11/07/2023	3-145-5-07-202	UTILITY STIPEND - BASEHOR NUTR	8.00		
770	BASEHOR UNITED	BASEHOR UNITED METHODIST CHURC	337456	105435 AP	11/07/2023	3-145-5-07-202	UTILITY STIPEND - BASEHOR NUTR	8.00		
								*** VENDOR	770 TOTAL	400.00
184	FLORENCE R	FLORENCE RIFORD SENIOR CTR	337460	105439 AP	11/07/2023	3-145-5-00-246	UTILITY STIPEND - MEALSITE	218.96		
184	FLORENCE R	FLORENCE RIFORD SENIOR CTR	337460	105439 AP	11/07/2023	3-145-5-05-202	UTILITY STIPEND - MEALSITE	90.16		
184	FLORENCE R	FLORENCE RIFORD SENIOR CTR	337460	105439 AP	11/07/2023	3-145-5-07-202	UTILITY STIPEND - MEALSITE	12.88		
								*** VENDOR	184 TOTAL	322.00
4755	LEAV PAPER	LEAVENWORTH PAPER AND OFFICE S	337582	105545 AP	11/09/2023	3-145-5-00-301	COA GLOSSY LABELS, BINDER	52.42		
4755	LEAV PAPER	LEAVENWORTH PAPER AND OFFICE S	337582	105545 AP	11/09/2023	3-145-5-00-301	COA GLOSSY LABELS, BINDER	8.83		
								*** VENDOR	4755 TOTAL	61.25
2059	MIDWEST OFFICE TECH	MIDWEST OFFICE TECHNOLOGY INC	337588	105551 AP	11/09/2023	3-145-5-00-208	OPK596_K COPIER	20.64		
2059	MIDWEST OFFICE TECH	MIDWEST OFFICE TECHNOLOGY INC	337588	105551 AP	11/09/2023	3-145-5-00-208	OPK596_K COPIER	421.53		
								*** VENDOR	2059 TOTAL	442.17
2666	MISC REIMBURSEMENTS	KAYLA LOUGHRY	337589	105552 AP	11/09/2023	3-145-5-00-205	MILEAGE - MOW DELIVERY	4.59		
276	WEX	WEX BANK	337613	74	11/09/2023	3-145-5-00-304	FUEL TO 10.23	4,727.74		
								TOTAL FUND 145		6,457.75
20588	ADVANTAGE	ADVANTAGE PRINTING	337494	105457 AP	11/09/2023	3-146-5-00-301	168 BLANK STATEMENTS WITH PERF	307.00		
								TOTAL FUND 146		307.00
243	GEOTAB	GEOTAB USA INC	337512	105475 AP	11/09/2023	3-153-5-00-401	LEAV01 OCTOBER GEOLOCATING SER	1,068.52		
								TOTAL FUND 153		1,068.52
243	GEOTAB	GEOTAB USA INC	337512	105475 AP	11/09/2023	3-155-5-00-403	LEAV01 OCTOBER GEOLOCATING SER	226.44		
								TOTAL FUND 155		226.44
243	GEOTAB	GEOTAB USA INC	337512	105475 AP	11/09/2023	3-160-5-00-215	LEAV01 OCTOBER GEOLOCATING SER	32.66		

warrants by vendor

START DATE: 11/04/2023 END DATE: 11/09/2023

TYPES OF CHECKS SELECTED: * ALL TYPES

			P.O.NUMBER	CHECK#					
22605	HINCKLEY S	HINCKLEY SPRINGS	337462	105441 AP	11/07/2023	3-160-5-00-263	5869900 WATER DELIVERY SOLIDWA	133.90	
461	LEAV CO CO	LEAV CO COOP	337580	105543 AP	11/09/2023	3-160-5-00-304	DIESEL FUEL	955.08	
								TOTAL FUND 160	1,121.64
8020	APCO INT'L	APCO INTERNATIONAL	337495	105458 AP	11/09/2023	3-174-5-00-202	444719I PUBLIC SFETY ONLINE CO	399.00	
1737	AT&T-CAROL STREAM IL	AT&T	337455	105434 AP	11/07/2023	3-174-5-00-210	KDOT SITE BONNER	366.30	
1737	AT&T-CAROL STREAM IL	AT&T	337455	105434 AP	11/07/2023	3-174-5-00-210	KDOT SITE BONNER	436.78	
								*** VENDOR 1737 TOTAL	803.08
								TOTAL FUND 174	1,202.08
933	LEXISNEXIS RELX	RELX INC	337584	105547 AP	11/09/2023	3-197-5-00-201	1001MUXAB LEGAL RESEARCH SUB T	7,440.00	
								TOTAL FUND 197	7,440.00
86	EVERGY	EVERGY KANSAS CENTRAL INC	337509	105472 AP	11/09/2023	3-212-5-00-2	ELEC SVC SEWER DIST 2	146.91	
86	EVERGY	EVERGY KANSAS CENTRAL INC	337509	105472 AP	11/09/2023	3-212-5-00-2	ELEC SVC SEWER DIST 2	34.86	
86	EVERGY	EVERGY KANSAS CENTRAL INC	337509	105472 AP	11/09/2023	3-212-5-00-2	ELEC SVC SEWER DIST 2	28.50	
86	EVERGY	EVERGY KANSAS CENTRAL INC	337509	105472 AP	11/09/2023	3-212-5-00-2	ELEC SVC SEWER DIST 2	59.11	
								*** VENDOR 86 TOTAL	269.38
								TOTAL FUND 212	269.38
86	EVERGY	EVERGY KANSAS CENTRAL INC	337509	105472 AP	11/09/2023	3-218-5-00-2	ELEC SVC SEWER DIST 5	66.12	
								TOTAL FUND 218	66.12
451	AETNA	AETNA LIFE INSURANCE COMPANY	337454	105433 AP	11/07/2023	3-510-2-00-939	108798268 OCTOBER PREMIUMS	346,722.21	
451	AETNA	AETNA LIFE INSURANCE COMPANY	337454	105433 AP	11/07/2023	3-510-2-00-939	108798268 OCTOBER PREMIUMS	10,194.60	
								*** VENDOR 451 TOTAL	356,916.81
1504	DELTA DENTAL OF KS	DELTA DENTAL OF KANSAS	337506	105469 AP	11/09/2023	3-510-2-00-942	51269-00001 NOVEMBER DENTAL PR	19,415.30	
1504	DELTA DENTAL OF KS	DELTA DENTAL OF KANSAS	337506	105469 AP	11/09/2023	3-510-2-00-942	51269-00001 NOVEMBER DENTAL PR	1,922.98	
								*** VENDOR 1504 TOTAL	21,338.28
1485	RELIANCE STANDARD	RELIANCE STANDARD	337468	105447 AP	11/07/2023	3-510-2-00-962	GROUP LIFE/VOL GROUP LIFE NOVE	1,667.72	
1485	RELIANCE STANDARD	RELIANCE STANDARD	337468	105447 AP	11/07/2023	3-510-2-00-965	GROUP LIFE/VOL GROUP LIFE NOVE	3,827.36	
								*** VENDOR 1485 TOTAL	5,495.08
								TOTAL FUND 510	383,750.17
								TOTAL ALL CHECKS	581,368.76

TYPES OF CHECKS SELECTED: * ALL TYPES

FUND SUMMARY

001	GENERAL	68,188.85
108	COUNTY HEALTH	5,295.60
115	EQUIPMENT RESERVE	1,173.69
119	ROD TECHNOLOGY	1,106.46
123	JUVENILE CRIME PREVENTION	25,489.84
126	COMM CORR ADULT	1,629.57
127	COMM CORR ADULT NON GRANT	.31-
133	ROAD & BRIDGE	45,492.57
136	COMM CORR JUVENILE	293.60
137	LOCAL SERVICE ROAD & BRIDGE	19,114.46
138	JUV INTAKE & ASSESSMENT	11,675.33
145	COUNCIL ON AGING	6,457.75
146	COUNTY TREASURER SPECIAL	307.00
153	PUBLIC WORKS,EQUIP.RESERVE FUND	1,068.52
155	LSR CAPITAL EQUIP RESERVE	226.44
160	SOLID WASTE MANAGEMENT	1,121.64
174	911	1,202.08
197	INK FEE FUND	7,440.00
212	SEWER DISTRICT 2: TIMBERLAKES	269.38
218	SEWER DIST #5	66.12
510	PAYROLL CLEARING	383,750.17
	TOTAL ALL FUNDS	581,368.76

Consent Agenda 11-15-2023
Checks 11/04 through 11/09





COUNTY OF LEAVENWORTH
BOARD OF COUNTY COMMISSIONERS

300 Walnut, Suite 225
Leavenworth, Kansas 66048-2815
(913) 684-0417
Facsimile (913) 684-0410
email: bocc@leavenworthcounty.org

November 15, 2023

KDOT Grant Administrators
Kansas Department of Transportation
Dwight D. Eisenhower State Office Building
700 SW Harrison St.
Topeka, KS 66603

RE: General Public Transportation Section 5310 Funds for Operating Grant fiscal year
July 2024-June 2025

This letter is written in support of The Guidance Center's application for a 5310 KDOT grant for operating and capital funds. This will greatly enhance the Center's ability to provide much needed service to the community.

It is our hope that the 5310 grant funds will be awarded at the highest possible level and appreciate the opportunity for The Guidance Center to apply.

Sincerely,

Vicky Kaaz, 2nd District, Chairperson

Doug Smith, 3rd District

Mike Smith, 4th District

Mike Stieben, 5th District

Jeff Culbertson, 1st District



COUNTY OF LEAVENWORTH
BOARD OF COUNTY COMMISSIONERS

300 Walnut, Suite 225
Leavenworth, Kansas 66048-2815
(913) 684-0417
Facsimile (913) 684-0410
email: bocc@leavenworthcounty.org

November 15, 2023

KDOT Grant Administrators
Kansas Department of Transportation
Dwight D. Eisenhower State Office Building
700 SW Harrison St.
Topeka, KS 66603

RE: General Public Transportation Section 5311 Funds for Operating Grant fiscal year
July 2024-June 2025

This letter is written in support of The Guidance Center's application for a 5311 KDOT grant for operating funds. This grant would assist with the partnership with the city of Leavenworth and The Guidance Center for "RideLV" and will greatly enhance the Center's ability to provide much needed service to the community.

It is our hope that the 5311 grant funds will be awarded at the highest possible level and appreciate the opportunity for The Guidance Center to apply.

Sincerely,

Vicky Kaaz, 2nd District, Chairperson

Doug Smith, 3rd District

Mike Smith, 4th District

Mike Stieben, 5th District

Jeff Culbertson, 1st District

Leavenworth County Request for Board Action

Date: 11/6/23

To: Board of County Commissioners

From: Buildings and Grounds

Department Head Approval: Aaron Yoakam

Additional Reviews as needed:

Budget Review Administrator Review Legal Review

Action Requested: Approve contract renewal with Symmetry Energy Solutions for natural gas service to Cushing Building

Recommendation: Approve

Analysis: Symmetry has proposed a 2 year contract holding the current cost for natural gas for both 2024 and 2025 calendar years. We have been with Symmetry since we took over the Cushing Building in late 2019. They have provided Natural gas without major issues since then and our department has had no issues with the service. The last 12 months total cost of the contract with Symmetry is \$20,983.23

Alternatives: decline option and seek alternative provider

Budgetary Impact:

- Not Applicable
- Budgeted item with available funds
- Non-Budgeted item with available funds through prioritization
- Non-Budgeted item with additional funds requested

Total Amount Requested: budget in 2024 budget for utilities

Additional Attachments: Quote proposal from Symmetry



Quote Proposal

Date: 09/20/2023
Quote Number: 00201470

The terms of this quote proposal are not binding and represent an offer from Seller to Buyer. Buyer may accept the terms of this quote proposal by providing written acceptance to Seller. In the event Buyer acknowledges the acceptance of this quote proposal and an agreement has been executed between Buyer and Seller, Seller will execute the quote proposal and issue a Transaction Confirmation to Buyer.

Seller:	Symmetry Energy Solutions, LLC	Buyer:	Leavenworth County
Address:	9811 Katy Fwy, Ste 1400	Address:	300 Walnut, Ste 106
City/State:	Houston, TX 77024-1296	City/State:	Leavenworth, KS 66048-2755
Attention:	Bob Webb		
Phone:	816-581-9096		
Fax:	(713) 393-0263		
Email:	bob.webb@symmetryenergy.com		

Base Contract No: EA-21087

Contract Price: Buyer's price will be IF Southern Star plus \$0.7274/MMBtu.

If on any day Buyer takes less volume than the Volume Commitment, Buyer shall be credited for the unused volumes at a per unit price equal to GDD Southern Star (the Incremental Under Price)

If on any day Buyer takes more volume than the Volume Commitment, Buyer shall be charged for the additional volumes at a per unit price equal to GDD Southern Star plus applicable fuel plus \$0.7274/MMBtu. (the Incremental Over Price)

Delivery Period: Begin: 12/01/2023 End: 11/30/2025

Performance Obligation: Firm. "Firm" means the utilization of a firm service agreement with a Transporter under which the transaction's Delivery Point is not a specified primary point for the delivery of Gas.

The Volume Commitment for a month will be allocated equally to each day thereof based on the number of days in such month.

Contract Quantity/Volume Commitment ("Volume Commitment")

<u>Month</u>	<u>Monthly Volume (MMBtu)</u>
Dec-2023	450
Jan-2024	839
Feb-2024	557
Mar-2024	297
Apr-2024	124
May-2024	37
Jun-2024	25
Jul-2024	18
Aug-2024	19
Sep-2024	3
Oct-2024	26
Nov-2024	174
Dec-2024	450
Jan-2025	839
Feb-2025	557
Mar-2025	297
Apr-2025	124
May-2025	37
Jun-2025	25
Jul-2025	18
Aug-2025	19
Sep-2025	3
Oct-2025	26
Nov-2025	174

Fees: Applicable Taxes
Transport Fuel: plus applicable fuel (Dec-2023 -)
Transport Demand: plus applicable transport demand (Dec-2023 -)

Dodd-Frank Transaction
Classification: Forward Contract

Delivery Point: Utility Citygate - KGS

Special Conditions:

Restrictive Order: The Parties acknowledge that an operational flow order, curtailment order, critical notice, or other governmental or Transporter directive concerning actual or potential limits or restrictions on the transportation, delivery, receipt, and/or use of Gas to, by, or for Seller, Buyer, or its affiliates (the 'RO Gas') or otherwise may occur (a 'Restrictive Order') with little to no advance notification. Each Party will comply with and take all commercially reasonable actions necessary to mitigate the impact of such Restrictive Order, and any charges or penalties assessed by a governmental authority or Transporter will be borne by the Party who failed to mitigate or comply with such Restrictive Order. A Restrictive Order may require, or may result in the need for (as reasonably determined by Seller), Seller to sell RO Gas to Buyer at a price subject to then-current market pricing, which may differ from the Contract Price set forth in an affected Transaction, and any such RO Gas will be priced and invoiced to Buyer (including any charges or penalties applicable thereto) as reasonably determined by Seller and paid by Buyer in accordance with the Base Contract. Seller shall deliver or receive RO Gas on a commercially reasonable basis, including subject to available transportation. For the avoidance of doubt, RO Gas will not be priced at the Contract Price and is not counted towards or subject to the Volume Commitment or Buyer's full requirements of, the affected Transaction. If Buyer fails to comply with a Restrictive Order, Buyer shall be responsible for compensating Seller for Gas, at pricing reasonably determined by Seller, to provide RO Gas or otherwise cover Buyer's receipt or use of Gas. Notwithstanding anything herein, if because of any Restrictive Order Seller is unable to deliver or Buyer is unable to receive all or a portion of the applicable Volume Commitment, then Seller will have no obligation to credit to or repurchase from Buyer any portion of such Volume Commitment. For the purposes of this Agreement, a 'Transporter' is the Gas gathering or pipeline company, or local distribution company, transporting Gas for Seller or Buyer upstream or downstream, respectively, of the Delivery Point(s) specified in a Transaction Confirmation.

Symmetry Energy Solutions, LLC certifies that it is not currently engaged in, and covenants that it will not, for the duration of this Transaction, engage in a Boycott of Israel.

Facilities:

Account numbers are accurate as of the Date above and may be modified by Utility/Pipeline

<u>Facility Name</u>	<u>Account Number</u>	<u>Meter Number</u>	<u>Address</u>	<u>City</u>	<u>State</u>
Leavenworth County - Cushing	510614745 1562996 051	1209426421/120196 1102	711 MARSHALL ST	LEAVENWOR TH	KS

Contract Price Symbols: "GDD" means Gas Daily Midpoint for the applicable delivery Day for the specified location. "GDA" means the average of Gas Daily Midpoint for the applicable delivery Month for the specified location. "IF" means Inside FERC's Gas Market Report, Index, first publication for the Month, for the delivery Month for the specified location. "NYMEX" means the New York Mercantile Exchange gas futures contract, Last Day Settle price, unless otherwise specified. "NGI" means NGI's Bidweek Survey, AVG, for the applicable delivery Month for the specified location. "Market Rate" means a delivered market-based rate for natural gas that is reasonably reflective of the geographic area in which the Delivery Point is located. "Utility Cashout" and "Pipeline Cashout" means applicable rates prescribed by the local distribution company, gas gathering or pipeline company.

Leavenworth County Request for Board Action

Date: November 8th, 2023

To: Board of County Commissioners

From: Public Works

Department Head Approval: WLN

Additional Reviews as needed:

Budget Review **Administrator Review** **Legal Review**

Action Requested: Approval of the agreement with Benesch to allow them to pay Dondlinger Construction directly for repairs to the F-46.

Recommendation: Approval

Analysis: Design errors resulted in the newly constructed F-46 bridge to not meet the contractually required and design engineer certified HL-93 load rating. This resulted in the new bridge being required to be posted for load. The additional work required to place two additional beams under the bridge and then pump epoxy between the bridge and deck will cost over \$71,000.

Finney and Turnipseed was hired to review Benesch's plan to ensure that the repairs would not decrease the lifespan of the structure and would meet the required HL-93 load rating. They approved of the proposed plan.

Alternatives:

Budgetary Impact:

- Not Applicable
- Budgeted item with available funds
- Non-Budgeted item with available funds through prioritization
- Non-Budgeted item with additional funds requested

Total Amount Requested: \$0

Additional Attachments: Agreement and supporting design

AGREEMENT FOR CONSTRUCTION SERVICES

F-46 Bridge Modifications

COME NOW the parties to this agreement, the board of county commissioners of the county of Leavenworth, Kansas (“County”) and Alfred Benesch & Company (Benesch), for additional construction services to be provided by Dondlinger Construction (“Contractor”) and through their respective authorized agents, and recite the following as the terms of the agreement between them.

1. **Purpose** The purpose of this agreement is to have Contractor perform modifications to bridge (F-46) owned by the County through the installation of additional steel girders to increase the structural capacity of this bridge.

2. **Payment** In return for the repair services to be performed by Contractor Benesch shall pay to Contractor a sum not to exceed \$71,800.00. Upon the completion of the construction work, Benesch shall submit to the County a paid invoice for the work performed by Contractor. The County shall have the opportunity to inspect the work performed by Contractor. Upon the acceptance of the work by the County, Benesch shall timely pay Contractor’s submitted invoice.

3. **Start Date/Completion Date** The start and completion dates for the construction services to be performed by Contractor are subject to the availability of the materials to Contractor and is tentatively anticipated to be completed by April 1, 2024. Benesch agrees to timely notify the County of the start and completion dates once provided by the contractor.

4. **Incorporation of Exhibits A and B** The letter dated October 11, 2023, and issued by Contractor, attached hereto as Exhibit A, setting out the scope of bridge modification services to be performed by Contractor and Exhibit B which contains additional contract provisions are hereby incorporated into this agreement.

5. **Traffic Control** Contractor shall timely notify the County of any impact on traffic on Bridge F-46, or the county roads serving that bridge, resulting from the work performed by Contractor. Contractor shall minimize the impact on traffic and shall be responsible for all proper traffic control signage as provided for by the MUTCD.

6. **Bonds and Insurance** Contractor will provide to the County a labor and materials bond in the amount of 100% of the contract price and a performance bond in the amount of 100% of the contract price. The performance bond shall be conditioned upon the performance by the Contractor of all undertakings, covenants, terms, conditions, and agreement of the contract documents. The payment bond shall be conditioned upon the prompt payment by the Contractor to all persons supplying labor and materials in the prosecution of the work provided by the contract documents and shall comply with the requirements of K.S.A. 60-1111. In addition, Contractor shall provide maintenance bond specifying that the bridge (F-46) shall endure without the need of repairs for a period of one-year from the completion of the modifications. Contractor shall provide all other bonds required under state law and shall maintain said bonds for a period of one-year from the completion of the modification, causing the County to be named as the beneficiary of said bonds. All bonds shall contain all terms and conditions in the contract documents and shall be executed by a surety company authorized to do business in the State of Kansas. Attorneys-in-fact who sign bonds must file with each bond a certified and effective dated copy of the power of attorney form.

The Contractor shall purchase and maintain during the term of this contract such insurance as will protect Contractor and the County from claims which may arise out of or result from the

Contractor's execution of the work, whether such execution be by himself or by any Subcontractor or by anyone directly or indirectly employed by any of them, or by anyone for whose acts any of them may be liable. The County shall be identified as an "additional named insured" or provided with an owner's protective policy written on an occurrence basis.

7. **Time of the Essence** The parties agree that upon the commencement of repair work by Contractor that the timely completion of said construction work is of the essence.

8. **Agreement as Contract** The parties agree that the terms of this agreement between them is enforceable as a contract and that each party shall have all of the responsibilities and remedies available under contract law.

AGREED TO THIS _____ DAY OF _____, 2023.

FOR COUNTY: _____

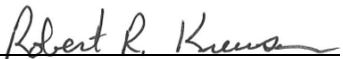
FOR BENESCH 
Robert R. Krewson, PE
Kansas Division Manager



October 11th, 2023

Jarrold Russell PE, CAMP
 Benesch
 11010 Haskell Avenue,
 Suite 200, Kansas City, KS 66109

F-46 Bridge Rehab – Proposal

Dondlinger Construction Bridge Division is pleased to provide this proposal for the rehab of bridge F-46 as detailed in attached drawing provided by Benesch.

Bid Item	Description	U/M	Quantity	U/P	Extension
001	Bridge F-46 Rehab	LS	1	\$71,800.00	\$71,800.00

Scope of work:

- All labor, equipment, material, and incidental costs necessary for the installation of two outer W18x97 beams, including welded on Diaphragms, L3x2x1/4" and L4x3x1/4" angles, and 1/2" plates.
- All labor, equipment, material, and incidental cost necessary for the installation of drilling core holes into the concrete deck and place Sikacrete 211 for concrete fillets.

Clarifications:

- 1 mobilization is included.
- This proposal assumes the ability to close 166th to traffic for the duration of the rehab.
- We have included x-ray of the existing deck to assist in locating existing rebar prior to coring holes into the deck.
- We have assumed weathering steel will be used for all structural steel in preparation of this proposal.
- Sales Tax is included.
- Construction schedule to be mutually agreed upon prior to the start of work.

Exclusions: Bond, Surveying, Staking, Permits, Sodding, Seeding, Erosion Control, NOI, SWPPP, Removal of Hazardous Waste, or any other item not listed in the scope of work.

Respectfully Submitted,

A handwritten signature in blue ink, appearing to read 'Aaron Carter', is written over a light blue horizontal line.

Aaron Carter
 Dondlinger Construction

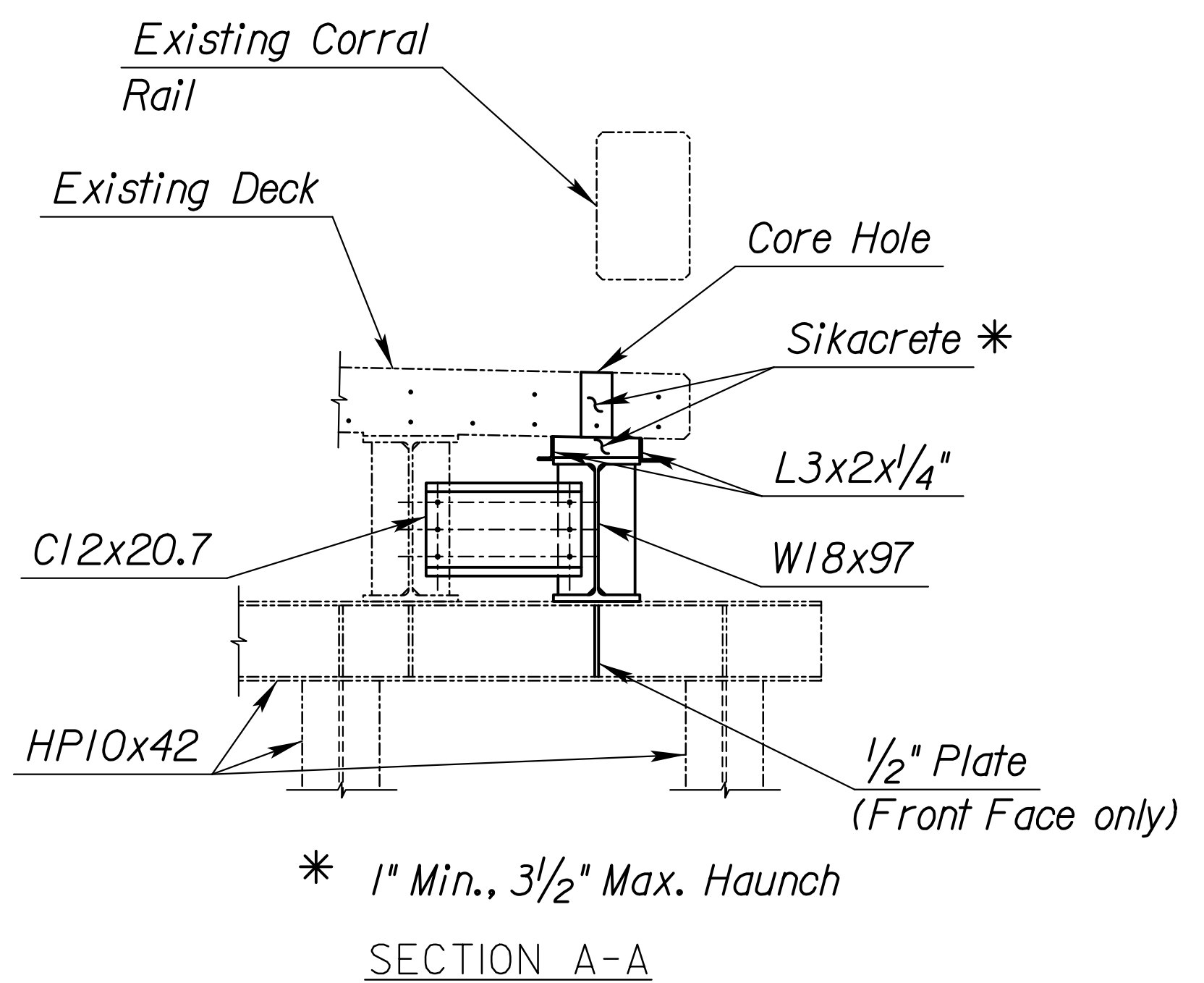
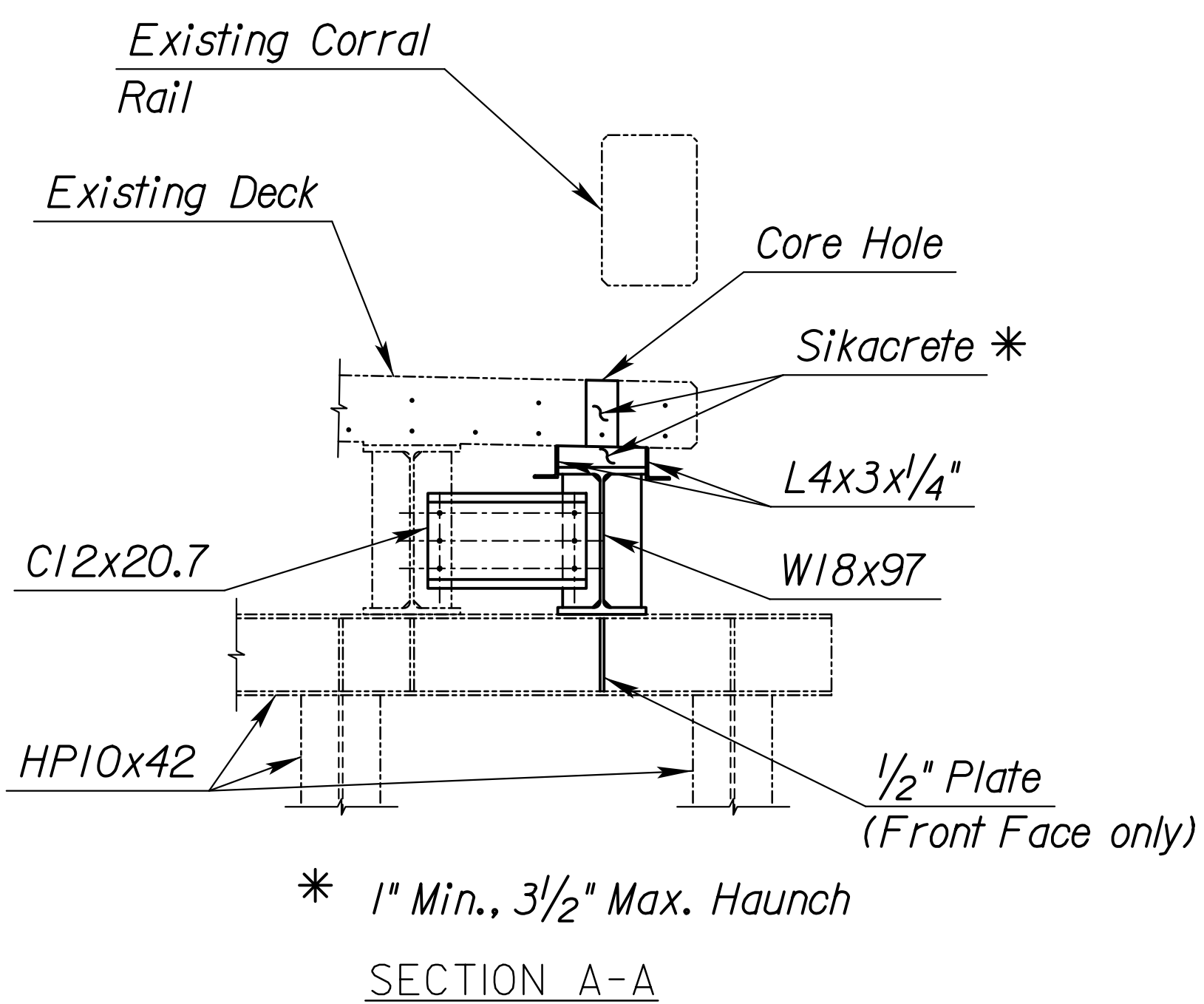
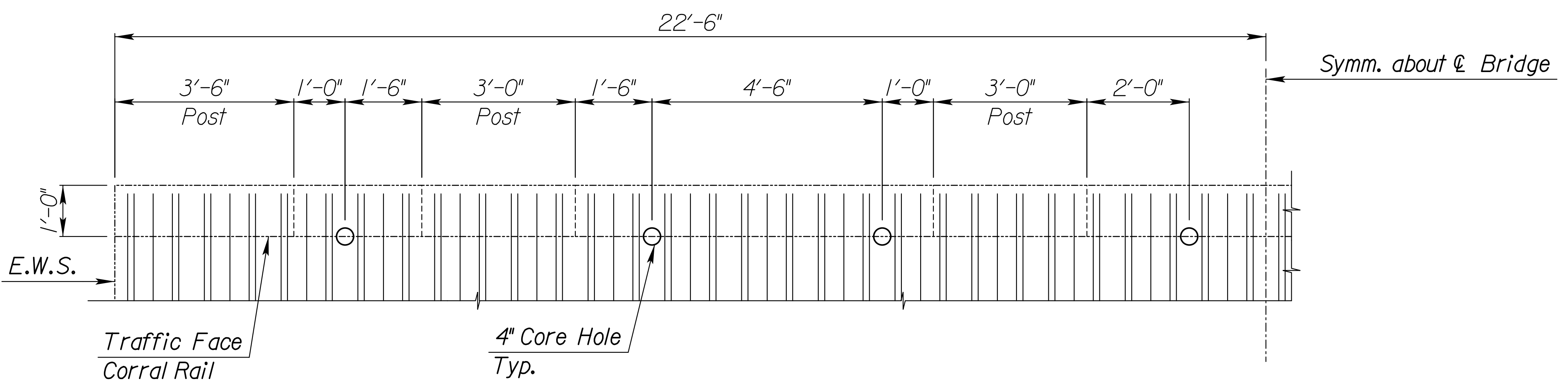
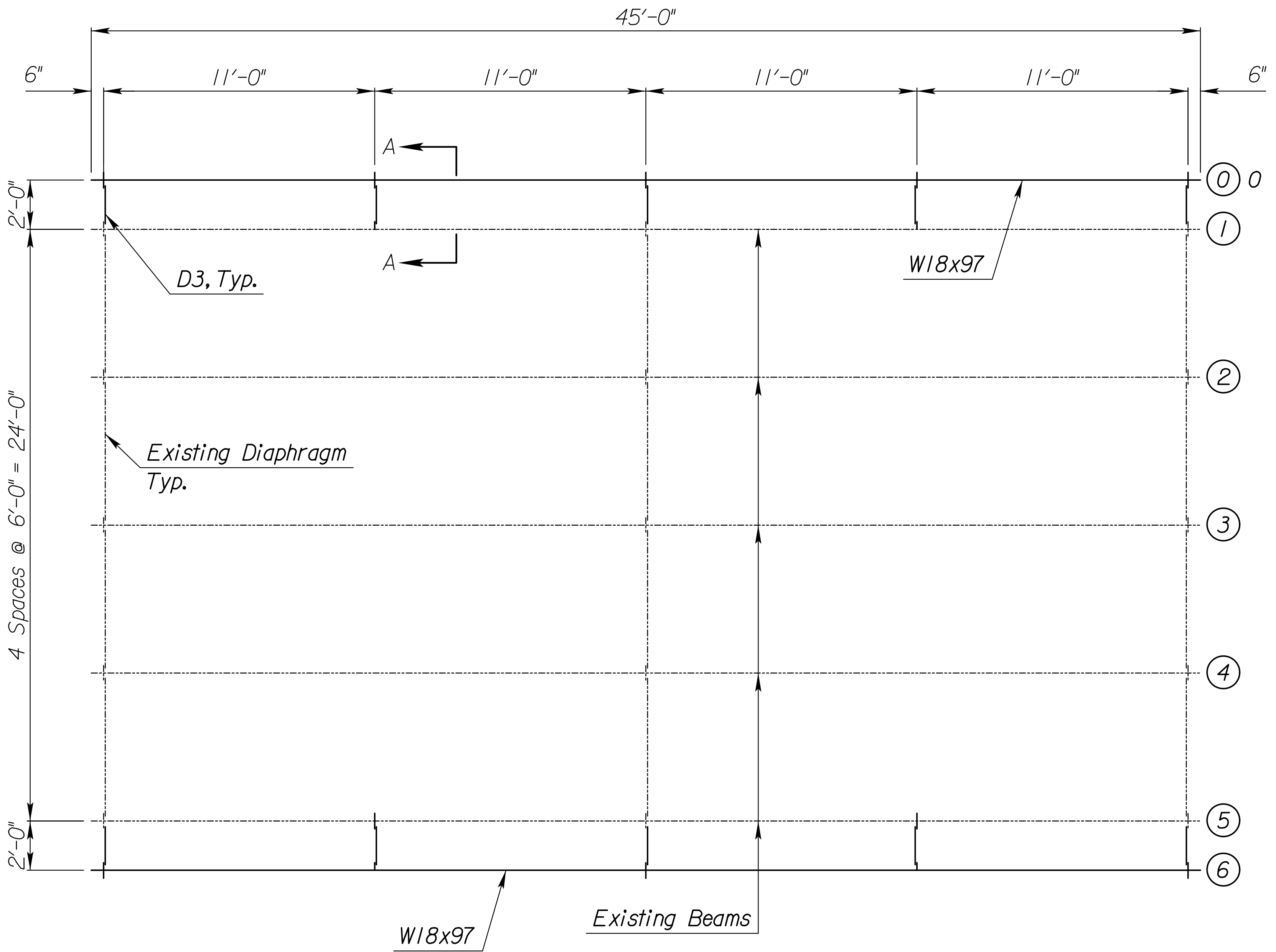

F-46 Bridge Modifications Narrative

In order to meet KDOT's current load posting requirements, additional structural capacity will be provided for the 166th Street Bridge over Hog Creek (referred to as Bridge F-46). The capacity will be increased through the addition of two new steel girders installed along the exterior of the existing bridge. One new girder will be placed along either side of the bridge located approximately underneath the existing bridge barrier. The new girders will be installed with little impact to the existing deck, superstructure, or substructure.

The new girders will be installed in a manner allowing loads from the existing deck to be distributed to them. New steel diaphragms will connect the new girders to existing ones, allowing the bridge to act as a single system. A few targeted cores will be drilled at the edge of the deck outside of the wheel paths to place structural grout along the surface between the top of the new girder and bottom of existing deck. The materials and procedures to be used have been proposed by the bridge engineer (Benesch) in coordination with bridge contractor (Dondlinger Construction) and reviewed by a third-party engineering firm (Finney & Turnipseed) who confirmed the methods and materials could be used in this application. Once installation is completed, the combined new and existing girders will share the loads from vehicles driving on the bridge. The shared loading will allow larger loads to traverse the bridge and not require it to be load posted.

During installation of the new girders, traffic across the bridge will be closed in order to allow the contractor access to complete this work. Upgrades to F-46 should be completed in less than two weeks based on conversations with contractor.

STATE	PROJECT NO.	YEAR	SHEET NO.	TOTAL SHEETS
KANSAS	130563.00	2023	I	I

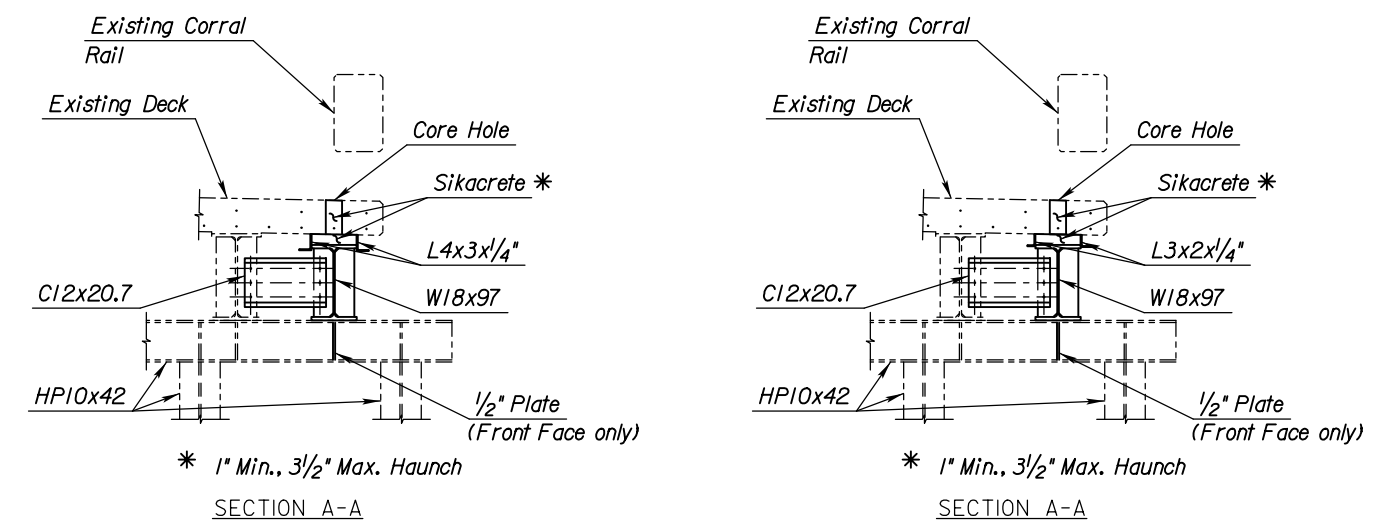
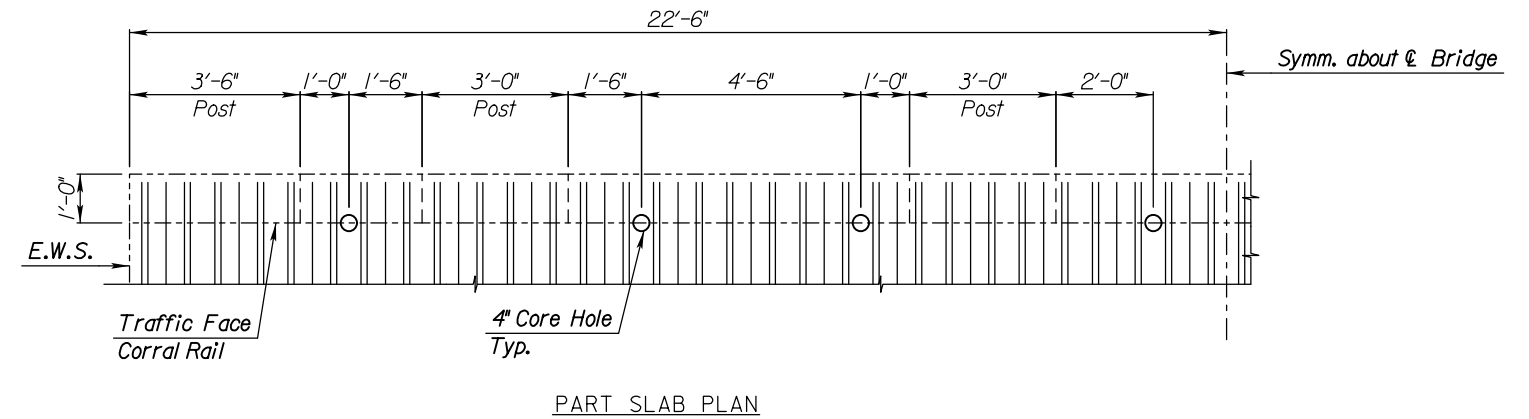
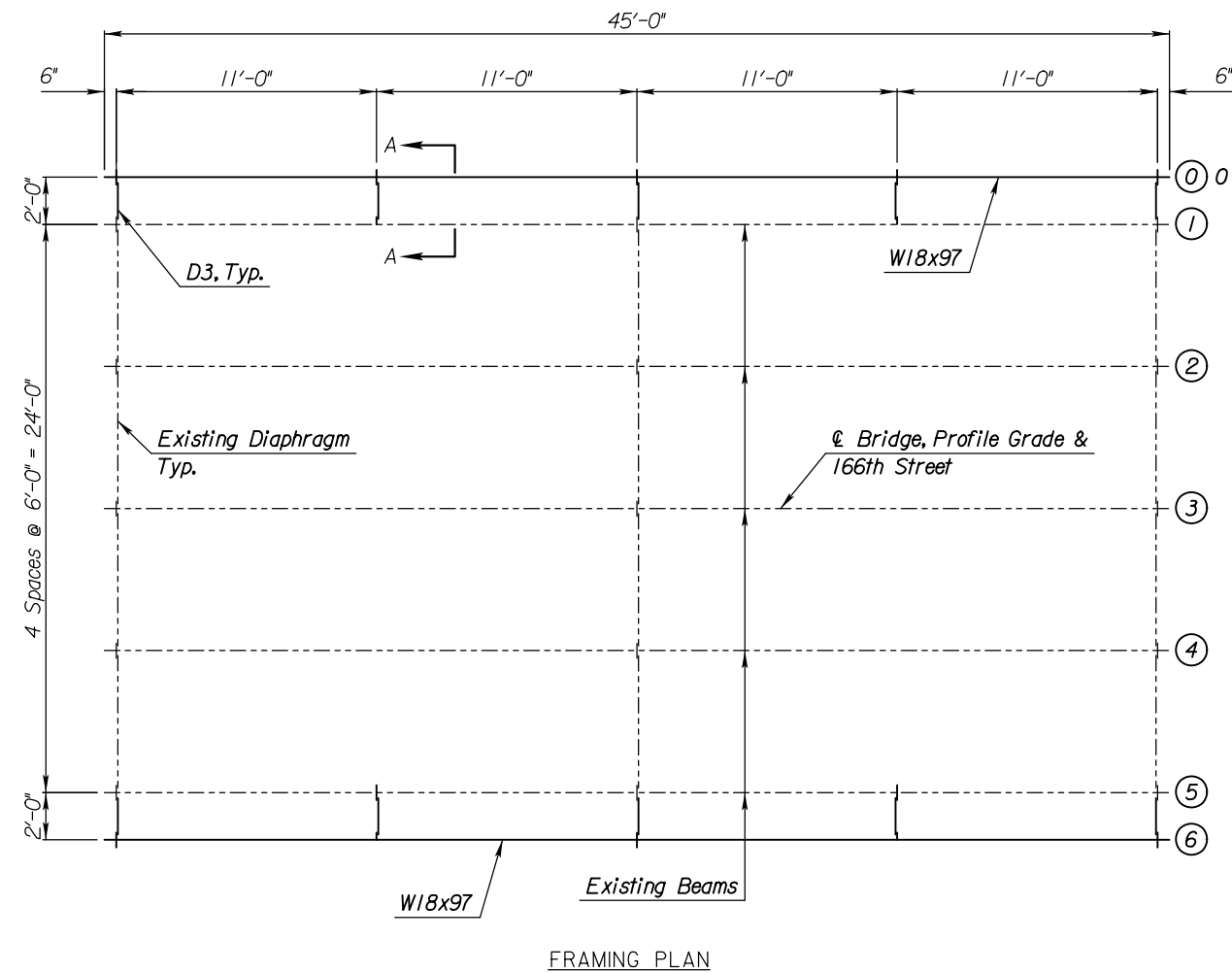

Notes:

- CONCRETE:** Contractor to use Sikacrete-211 or similar concrete. Follow the manufacturer's directions for mixing, application, and curing.
- TRAFFIC CONTROL:** Traffic shall be closed during construction. Construction signing shall be furnished and maintained by the Contractor.
- TEMPERATURE:** The design temperature for all dimensions is 60°F.
- DIMENSIONS:** All dimensions shown on the design plans are horizontal unless otherwise noted. Make necessary allowances for roadway grade and cross slope.
- SAW CUTS:** All saw cuts shall be subsidiary to other items in the Contract.

REINFORCING IN BRIDGE DECK: Care should be exercised to prevent cutting, stretching, or damaging exposed reinforcing steel. Extreme care should be exercised to avoid breaking the bond between the reinforcing steel and concrete where bars are partially exposed yet remain anchored in sound concrete. Reinforcing steel damaged, cut or deteriorated shall be replaced as directed by the Engineer. Do not wedge chipping hammer bit against reinforcement. Replacement of bars damaged by the Contractor shall be at no cost to the Prime.

UNIT STRESSES:

- Concrete (Grade 4.0) $f'_c = 4.0$ ksi
- Reinforcing Steel (Grade 60)(Epoxy Coated) $f_y = 60,000$ psi
- Structural Steel A709 Gr. 50W $f_y = 50$ ksi
- Structural Steel AASHTO M270 Gr. 50WT3 $f_y = 50$ ksi

Plotted By: JRussell
 File: details.dgn
 Plot Date: 17-OCT-2023 09:11

3				
2				
1				
NO.	DATE	REVISIONS	BY	APP'D
KANSAS DEPARTMENT OF TRANSPORTATION Br. No. F-46 Sta. 50+00.00 BRIDGE F-46 MODIFICATIONS 166th STREET OVER HOG CREEK Proj. No. 130563.00 Leavenworth Co.				
SHEET NO. 1 OF 1	SCALE	APP'D	DESIGNED	QUANTITIES
DESIGN CK.	DETAIL CK.	QUAN. CK.	CADD CK.	CADD CK.

EXHIBIT B

LEAVENWORTH COUNTY
GENERAL CONTRACTUAL PROVISIONS

As it relates to the Agreement for Construction Services for the F-46 Bridge Modifications, all instances of “Contractor” in this Exhibit B shall be replaced with “Benesch”. Benesch shall be responsible for flowing down these General Contractual Provisions to the Contractor.

1. **Terms Herein Controlling Provisions:** It is expressly agreed that the terms of each and every provision in this attachment shall prevail and control over the terms of any other conflicting provision in any other document relating to and a part of the agreement in which this attachment is incorporated. Any terms that conflict or could be interpreted to conflict with this attachment are nullified.
2. **Governing Law and Venue.** This Agreement is subject to, governed by, and construed according to the laws of the State of Kansas. Jurisdiction and venue of any suit in connection with the Agreement shall reside only in courts located in Leavenworth County, Kansas
3. **Compliance with Law.** Contractor shall comply with all applicable local, state, and federal laws and regulations in carrying out this Agreement, regardless of whether those legal requirements are specifically referenced in this Agreement.
4. **Modification of Agreement.** This Agreement may be modified or amended only in writing executed by both parties and will be subject to renegotiation in the event of changes to applicable law, rules, or regulations affecting the subject matter of this Agreement.
5. **Assignment.** Neither the Contractor nor the County shall, sell, transfer, assign, or otherwise dispose of any rights or obligations created by this Agreement without the written consent of the other party.
6. **Cash Basis Law.** This Agreement is subject to the Kansas Cash Basis Law, K.S.A. 10-1101 *et seq.* and amendments thereto. Any automatic renewal of the terms of the Agreement shall create no legal obligation on the part of the County. This Agreement shall be construed and interpreted so as to ensure that the County shall at all times stay in conformity with such laws and, as a condition of this Agreement, the County reserves the right to unilaterally sever, modify, or terminate this Agreement at any time if, in the opinion of its legal counsel, the Agreement is deemed to violate the terms of such law. The County is obligated only to pay periodic payments or monthly installments under the Agreement as may lawfully be made from (a) funds budgeted and appropriated for that purpose during the County's current budget year or (b) funds made available from any lawfully operated revenue producing source.
7. **Payment of Taxes.** The County shall not be responsible for, nor indemnify the Contractor for any federal, state, or local taxes which may be imposed or levied upon the subject matter of this Agreement.

Mandatory General Contractual Provisions

8. **Licenses and Permits.** Contractor shall maintain all licenses, permits, certifications, bonds, and insurance required by federal, state, or local authority for carrying out this Agreement. Contractor shall notify the County immediately if any required license, permit, bond, or insurance is cancelled, suspended, or is otherwise ineffective. Such cancellation, suspension, or other ineffectiveness may form the basis for immediate termination by the County in its discretion.

9. **Independent Contractor Relation.** The parties agree that the legal relationship between them is of a contractual nature. Nothing in this Agreement shall be construed to create a relationship of employer and employee or principal and agent or any other relationship other than that of independent parties contracting with each other solely for the purpose of carrying out the provisions of this Agreement. Nothing in this Agreement shall create any right or remedies in any third party. The parties agree that no persons supplied by the Contractor are employees of the County and that no right of the County's civil service, retirement, or personnel rules accrue to such persons. The County shall not be responsible for withholding of social security, workers compensation insurance, unemployment compensation, bonuses, retirement benefits, other benefits, and any taxes and premiums from any payments made by the County to the Contractor.

10. **Anti-Discrimination Clause:** Contractor agrees: (a) to comply with the Kansas Act Against Discrimination (K.S.A. 44-1001 et seq.) and the Kansas Age Discrimination in Employment Act (K.S.A. 44-1111 et seq.) and the applicable provisions of the Americans With Disabilities Act (42 U.S.C. 12101 et seq.) (ADA), and Kansas Executive Order No. 19-02, and to not discriminate against any person because of race, color, gender, sexual orientation, gender identity or expression, religion, national origin, ancestry, age, military or veteran status, disability status, marital or family status, genetic information, or political affiliation that is unrelated to the person's ability to reasonably perform the duties of a particular job or position; (b) to include in all solicitations or advertisements for employees, the phrase "equal opportunity employer"; (c) to comply with the reporting requirements set out at K.S.A. 44-1031 and K.S.A. 44-1116; (d) to include those provisions in every subcontract or purchase order so that they are binding upon such subcontractor or vendor; (e) that a failure to comply with the reporting requirements of (c) above or if the contractor is found guilty of any violation of such acts by the Kansas Human Rights Commission, such violation shall constitute a breach of contract and the agreement may be cancelled, terminated or suspended, in whole or in part, by the contracting state agency or the Kansas Department of Administration; (f) if it is determined that the Contractor has violated applicable provisions of ADA, such violation shall constitute a breach of contract and the agreement may be cancelled, terminated or suspended, in whole or in part, by the University or the Kansas Department of Administration.

Contractor agrees to comply with all applicable state and federal anti-discrimination laws.

The provisions of this paragraph number 10 (with the exception of those provisions relating to the ADA) are not applicable to a Contractor who employs fewer than four employees during the term of such contract or whose contracts with the contracting State agency cumulatively total \$5,000 or less during the fiscal year of such agency.

Mandatory General Contractual Provisions

11. **Representative's Authority To Contract.** By signing this contract, the representative of Contractor thereby represents that such person is duly authorized by Contractor to execute this contract on behalf of Contractor and that Contractor agrees to be bound by the provisions thereof.
12. **Waiver of Breach.** The waiver by either party of a breach of any provision of this Agreement will not operate or be construed as a waiver of any subsequent breach by such party.
13. **Severability.** If a court of competent jurisdiction declares any part of this Agreement to be invalid, the balance of the agreement will remain valid and enforceable.
14. **Entire Agreement.** This Agreement and its attachments set forth the parties' entire agreement. Neither party has made any oral or side agreements or representations not contained in this Agreement. This is a legal document and not a mere recital and is binding upon the parties, their representatives, and successors in interest.
15. **Disclaimer of Liability.** The County shall not hold harmless or indemnify the Contractor for any liability whatsoever. No provision of this Agreement will be given effect that attempts to require the County to defend, hold harmless, or indemnify any contractor or third party for any acts or omissions. The liability of the County is defined under the Kansas Tort Claims Act (K.S.A. 75-6101 et seq.).
16. **Termination for Default.** If the Contractor refuses or fails to perform any of the provisions of this Agreement with such diligence as will ensure its completion within the time specified in this Agreement, or any extension thereof, or commits any other substantial breach of this Agreement, the County may notify the Contractor in writing of the delay or nonperformance and, if not cured in ten days or any longer time specified in writing by the County, the County may terminate the Contractor's rights to proceed with the Agreement or such part of the Agreement as to which there has been delay or a failure to properly perform.

The County shall pay the Contractor the costs and expenses and reasonable profit for services performed by the Contractor prior to receipt of the notice of termination; however, the County may withhold from amounts due the Contractor such sums as the County deems to be necessary to protect the County against loss caused by the Contractor because of the default.

Except with respect to defaults of subcontractors, the Contractor shall not be in default by reason of any failure in performance of this Agreement in accordance with its terms if the Contractor has notified the County within 15 days of the cause of the delay and the failure arises out of causes such as acts of God, acts of the public enemy, act of the County and any other governmental entity in its sovereign or contractual capacity, fires, floods, epidemics, quarantine restrictions, strikes, or other labor disputes. If the failure to perform is caused by the failure of a subcontractors to perform or to make progress, and if such failure arises out of causes similar to those set forth above, the Contractor shall not be deemed to be in default, unless the services to be furnished by the subcontractors were reasonably obtainable from other sources in sufficient time to permit the Contractor

Mandatory General Contractual Provisions

to meet the contract requirements Upon request of the Contractor, the County shall ascertain the facts and extent of such failure, and, if such officer determines that any failure to perform was occasioned by any one or more of the excusable causes, and that, but for the excusable cause, the Contractor's progress and performance would have met the terms of the Agreement, the time for completion of the Agreement shall be revised accordingly.

If, after notice of termination of the Contractor's right to proceed under the provisions of this clause, it is determined for any reason that the Contractor was not in default under the provisions of this clause, and both the County and the Contractor agree, the rights and obligations of the parties shall be the same as if the notice of termination had not been issued.

The following acts committed by the Contractor will constitute a substantial breach of the Agreement and may result in termination of the Agreement:

- If the Contractor is adjudged bankrupt or insolvent;
- If the Contractor makes a general assignment for the benefit of his creditors;
- If a trustee or receiver is appointed for the Contractor or any of his property;
- If the Contractor files a petition to take advantage of any debtor's act or to reorganize under bankruptcy or applicable laws;
- If the Contractor repeatedly fails to perform in accordance with the standard of care;
- If the Contractor disregards the authority of the County;
- Acts other than those specified may constitute substantial breach of this Agreement.

17. **Termination for Convenience.** The County may, when the interests of the County so require, terminate this contract in whole or in part, for the convenience of the County. The County shall give written notice of the termination to the Contractor specifying the part of the contract terminated and when termination becomes effective.

The Contractor shall incur no further obligations in connection with the terminated work and on the date set in the notice of termination the Contractor will stop work to the extent specified. The County shall pay the Contractor the following amounts:

All costs and expenses incurred by the Contractor for work accepted by the County prior to the Contractor's receipt of the notice of termination, plus a reasonable profit for said work.

All costs and expenses incurred by the Contractor for work not yet accepted by the County but performed by the Contractor prior to receipt of the notice of termination, plus a reasonable profit for said work.

Mandatory General Contractual Provisions

Anticipatory profit for work and services not performed by the Contractor shall not be allowed.

18. **Arbitration, Damages and Warranties.** Notwithstanding any language to the contrary, no interpretation of this Agreement shall find that the County has agreed to binding arbitration, or the payment of damages or penalties. Further, the County does not agree to pay attorney fees, costs, or late payment charges beyond those available under the Kansas Prompt Payment Act (K.S.A. 75-6403), and no provision will be given effect that attempts to exclude, modify, disclaim or otherwise attempt to limit any damages available to the County at law, including but not limited to the implied warranties of merchantability and fitness for a particular purpose.
19. **Ownership of Materials.** All property rights, including publication rights, in all interim, draft, and final reports and other documentation, including machine-readable media, produced by the Contractor in connection with the work pursuant to this Agreement, shall be in the County.
20. **Availability of Records and Audit.** The Contractor agrees to maintain books, records, documents, and other evidence pertaining to the costs and expenses of the services provided under the Agreement (hereinafter collectively called "records") to the extent and in such detail as will properly reflect all net costs, direct and indirect, of labor, materials, equipment, supplies, and services, and other costs and expenses of whatever nature for which reimbursement is claimed under the provisions of this Agreement. The Contractor agrees to make available at the offices of the County at all times during the period set forth in the Request for Proposals any of the records for inspection, audit, or reproduction by any authorized representative of the County. Except for documentary evidence delivered to the offices of the County, the Contractor shall preserve and make available to persons designated by the County his records for a period of three years from the date of final payment under the Agreement or until all audit questions have been resolved, whichever period of time is longer.
21. **No Limit of Liability.** Nothing in this Agreement shall be construed to limit the Contractor's liability to the County as such liability may exist by or under operation of law.
22. **Indemnification.** Contractor shall indemnify, defend, and hold the County harmless from and against all claims, losses, damages, to the extent caused by Contractor's negligent acts, errors or omissions, or breach of the foregoing warranties. This indemnification shall not be subject to any limitations of remedies or warranties which are contained in this or any other agreement and shall survive termination of this or any other agreement between the parties hereto or thereto.
23. **Authority to Contract.** Contractor represents that it possesses legal authority to contract, that it has undertaken any official action required by its governing documents to enter into this Agreement, that its undersigned representative is duly authorized to execute this document on its behalf, that it agrees to be bound by all the provisions of this Agreement, and that the person identified as its official representative is authorized to act on its behalf in the implementation of this Agreement.

Leavenworth County Request for Board Action

Date: November 9, 2023

To: Board of County Commissioners

Cc: Mark Loughry; David Van Parys

From: Misty Brown, County Counselor

Department Head Approval:

Additional Reviews as needed:

Budget Review **Administrator Review** **Legal Review**

Action Requested: Consideration of an Amended Resolution revising Section 4 (a)(8) of Resolution 2023-24 to provide for the general composition of the Juvenile Corrections Advisory Board (JCAB) and allow for additional members as authorized by state statute.

Recommendation: Consideration of the Resolution.

Analysis: On September 13, 2023, the Board of County Commissioners of Leavenworth County established a Leavenworth County JCAB pursuant to state statute with membership as required by state statute and repealed and rescinded Resolution 1999-7. On November 1, 2023, the Board of County Commissioners appointed three members and an educational representative to the Leavenworth County JCAB and directed staff to bring forward a resolution amending Section 4 (a)(8) to provide for the composition of the JCAB by allowing additional Commission appointments as authorized by state statute. This amended resolution, if adopted, will replace 2023-24.

Alternatives: Table, Deny or Approve

Budgetary Impact:

- Not Applicable
- Budgeted item with available funds
- Non-Budgeted item with available funds through prioritization
- Non-Budgeted item with additional funds requested

Total Amount Requested: Incidental publication costs

Additional Attachments:

Resolution

RESOLUTION NO. 2023-31

A RESOLUTION OF THE BOARD OF COUNTY COMMISSIONERS OF LEAVENWORTH COUNTY, KANSAS ADOPTING AN AMENDED RESOLUTION REVISING SECTION 4(a)(8) OF RESOLUTION 2023-24 WHICH ESTABLISHED A LEAVENWORTH COUNTY JUVENILE CORRECTIONS ADVISORY BOARD AND REPEALED RESOLUTION 1999-7.

WHEREAS, state statutes, specifically K.S.A. 75-7038 through 75-7053 and amendments thereto, provide for the establishment of a local juvenile corrections advisory board by counties; and

WHEREAS, K.S.A. 75-7044 and amendments thereto provide for the general composition of such boards, allowing for additional members other than those set out in statute; and

WHEREAS, on September 13, 2023, the Board of County Commissioners of Leavenworth County established a Leavenworth County Juvenile Corrections Advisory Board pursuant to state statute with membership as required by state statute and repealed and rescinded Resolution 1999-7; and

WHEREAS, on November 1, 2023, the Board of County Commissioners of Leavenworth County appointed three members and an educational representative to the Leavenworth County Juvenile Corrections Advisory Board; and

WHEREAS, the Board of County Commissioners of Leavenworth County wishes to amend Section 4 (a)(8) of Resolution 2023-24 to provide for the general composition of the Juvenile Corrections Advisory Board and allow for additional members as authorized by state statute.

NOW, THEREFORE, THE BOARD OF COUNTY COMMISSIONERS OF LEAVENWORTH COUNTY, KANSAS, SITTING IN REGULAR SESSION, DOES HEREBY RESOLVE THAT THE FOLLOWING AMENDED RESOLUTION BE ADOPTED REPLACING RESOLUTION 2023-24:

Section 1. Establishment of Juvenile Corrections Advisory Board.

There is hereby created the Leavenworth County Juvenile Corrections Advisory Board, (hereinafter referred to as “JCAB”).

Section 2. Repeal of Prior Resolutions.

That Resolution 1999-7 is hereby repealed and rescinded. To the extent any provisions of prior Resolutions contradict with this Resolutions, those provisions are hereby repealed and rescinded as it is the intent of the Board of County Commissioners that the provisions of this Resolution superseded those resolutions and replace them in their entirety.

Section 3. Purpose and Duties.

The JCAB shall:

- (a) Annually consider the availability of treatment programs, programs creating alternatives to incarceration for juvenile offenders, mental health treatment, and the development of risk assessment tools, if they do not currently exist, for use in determining pretrial release and probation supervision levels.
- (b) Report to the Kansas department of corrections and the Kansas Juvenile Justice oversight committee by October 1 of each year detailing the costs of programs needed in the 1st Judicial District to reduce the out-of-home placement of juvenile offenders and improve the rate of recidivism of juvenile offenders in such judicial district.
- (c) Adhere to the goals of the juvenile justice code as provided in K.S.A. 38-2301, and amendments thereto and coordinate with the Kansas juvenile justice oversight committee created in K.S.A. 75-52,161.
- (d) Actively participate in the continuing formulation of the comprehensive plan for the development, implementation, and operation of juvenile correctional services as described in K.S.A. 75-7038 and amendments thereto.
- (e) Make formal recommendations to the Leavenworth County Board of Commissioners at least annually concerning the comprehensive plan and its implementation and continuing operation.
- (f) Advise the Leavenworth County Board of Commissioners on any and all matters touching upon juvenile corrections.

Section 4. Composition of the JCAB.

The JCAB shall be composed of voting members appointed as follows:

- (a) Members shall assume positions on the JCAB pursuant to statutory requirements of K.S.A. 75-7044 and amendments thereto as follows:

- (1) The Sheriff or the Sheriff's designated representative;
 - (2) The Chief of Police of Leavenworth, Kansas, or the Chief of Police's designated representative;
 - (3) The County Attorney or the County Attorney's designated representative;
 - (4) A District Court Judge assigned to the juvenile court docket appointed by the Administrative Judge of the 1st Judicial District;
 - (5) An education professional appointed by the Leavenworth County Board of County Commissioners;
 - (6) A court Services officer designated by the judge of the 1st Judicial District who is assigned the juvenile court docket or the judge who is assigned most juvenile court cases;
 - (7) The executive director of the community mental health center or such director's designated representative;
 - (8) As the governing body for the county, the Leavenworth County Board of Commissioners shall appoint at least three (3) members and no more than six (6) additional members to the Board pursuant to the statutory requirements of K.S.A. 75-7044 and amendments thereto;
 - (9) The City of Leavenworth, Kansas shall be invited to designate three representatives to the JCAB. If the City fails to designate such representative(s), the Leavenworth County Board Commissioners may appoint representative(s) to fill such position;
 - (10) A juvenile defense representative that is a practicing juvenile defense attorney in the judicial district and selected by the judge of the 1st Judicial District who is assigned the juvenile court docket.
- (b) To the extent possible, JCAB members appointed by the Leavenworth County Board of Commissioners shall be representatives of one or more of the following:
- (1) Public or private social services agencies;
 - (2) Ex-offenders;
 - (3) The health care professions; and
 - (4) The general public.

- (c) At least two members of the JCAB shall be representative of ethnic minorities and no more than 2/3 of the members of the JCAB shall be members of the same gender.

Section 5. Term and Vacancies.

- (a) The term of the JCAB members shall be for three years from the effective date of this Resolution or until their successors are appointed and qualified.
- (b) All vacancies on the Board shall be filled for the unexpired term in the manner that the position was originally filled.

Section 6. Proceedings and Records Opens; Votes Recorded.

- (a) All proceedings of the JCAB and any committee or subcommittee of the JCAB shall be open to the public pursuant to K.S.A. 75-7045 and any amendments thereto.
- (b) All votes of members of the JCAB shall be recorded and shall become matters of public record.
- (c) All other records of the Board shall be open to public inspection pursuant to K.S.A. 45-215 et seq., the Kansas Open Records Acts and any amendments thereto, unless disclosure is or may be restricted under state or federal law.

Section 7. Meeting Quorum; Voting; Proxies; Attendance.

- (a) The JCAB shall hold regular meetings at a time and place to be determined by the JCAB. Additional and special meetings may be called by the Chair at any time. Notice of additional or special meetings, either oral or written shall be give to each JCAB meeting at least 48 hours before the meeting.
- (b) A quorum shall be majority of voting members of the JCAB. A quorum must be present at any meeting at which official JCAB action is taken.
- (c) The JCAB may take action only by a vote of a majority of the voting members present at a meeting at which a quorum exists.
- (d) Each member of the JCAB, in writing, may designate a proxy who may attend meetings and cast votes in the place of the member.

(e) If any JCAB member fails to attend two regular meetings during the State fiscal year and fails to send a proxy to such meetings, the Chair will consult with the JCAB member in writing as to the JCAB member's intention to continue in the position. If any JCAB member fails to attend three regular meetings in a State fiscal year and fails to send a proxy for such meetings, the JCAB member will be deemed to have forfeited his or her position. Such position will be filled under Section 5 of this Resolution.

Section 8. Officers.

The Board shall elect its own officers.

Section 9. Conflict. All resolutions, County Policies or parts thereof, in conflict herewith are hereby expressly repealed insofar as they conflict herewith.

Section 10. Effective Date.

This Resolution shall take effect immediately upon adoption by the Leavenworth County Board of County Commissioners.

The County Administrator, and Leavenworth County's other officers, agents, and employees are hereby authorized and directed to take such further action, and execute such other documents, certificates, and instruments as may be necessary or desirable to carry out and comply with the intent of this Resolution.

ADOPTED the _____ day of November, 2023.

**BOARD OF COUNTY COMMISSIONERS
OF LEAVENWORTH COUNTY, KANSAS**

VICKY KAAZ, CHAIR

JEFF CULBERTSON, MEMBER

MIKE SMITH, MEMBER

DOUG SMITH, MEMBER

MIKE STIEBEN, MEMBER

ATTEST:

LEAVENWORTH COUNTY CLERK